



Continuous Band Sealer Instruction Manual

Distributed By:

Version 3.6
Last Updated: November 16, 2021

Copyright © 2014 by Stephanie Hwang

All rights reserved. No part of this publication may be reproduced, distributed, or transmitted in any form or by any means, including photocopying, recording, or other electronic or mechanical methods, without the prior written permission of the publisher, except in the case of brief quotations embodied in critical reviews and certain other noncommercial uses permitted by copyright law. For permission requests, write to the publisher, addressed "Attention: Permissions Coordinator," at the address below.

Sealer Sales, Inc.
8820 Baird Avenue
Northridge, Ca 91324
www.sealersales.com

Printed in the United States of America

General Information

Thank you for purchasing our continuous band sealer.

This owner's manual contains information relating to your band sealer machine. The manual will provide you with basic information concerning both operation and maintenance of your new machine. Please read it carefully as failure to do so may result in bodily injury and/or damage to the equipment.

Please fill in the information below. You will find the information on the machine identification plate. You will need this information when ordering replacement parts or making technical inquiries.

No part of this manual may be duplicated, reproduced, stored in a retrieval system, translated, transcribed, or transmitted in any form without the express prior written permission of Sealer Sales.

EQUIPMENT INFORMATION

❖ Model #

❖ Serial #

❖ Purchase Date:

❖ Reference # (found on packing slip)

❖ Owner:

Table of Contents

Safety Instructions	1
Introduction.....	3
Installation.....	8
Operating your Band Sealer.....	10
Maintenance.....	23
FRM-1120C Parts Diagram	26
FRS-1120W Parts Diagram.....	39
Troubleshooting.....	48
Spare Parts List.....	56
Quality Control Testing.....	57

Safety Instructions



WARNING! *Below are general safety precautions and warnings that should be understood prior to setting up or operating your equipment. Read and fully understand all instructions and warnings prior to using this unit. Your safety is most important! Failure to comply with procedures may result in serious injury or property damage. Remember: Your personal safety is your responsibility.*

Unsafe practices or unauthorized modifications could result in accidents or property damage. Failure to follow these safety rules and take necessary precautions can result in serious injury as well as damage to equipment.

- ❖ Never operate or service your band sealer until you have read this manual completely and understand it fully.

- ❖ Do not use the band sealer if the power cord, plug or any other parts are damaged. Be sure not to allow the power cord to drape into your work area. Check that all parts are operating properly and perform the intended functions. Check for all other conditions that may affect the operation.
- ❖ Reduce risk of unintentional starting. Make sure the power switch is in the "OFF" position before attaching to the power source.
- ❖ Always disconnect sealer from power source before servicing, changing accessories or cleaning the unit.
- ❖ To provide protection against the risk of electrical shock, the power connection must be properly grounded at all times.
- ❖ Do not leave the sealer unattended when in use. Disconnect the sealer from the power source before leaving the work area.
- ❖ Band sealer is used solely for sealing thermoplastic materials. Using the machine for any other purpose can cause damage to the machine and operator.
- ❖ Always operate machine on a flat stable surface.
- ❖ While operating machinery, wear close-fitting clothing and tie back long hair to prevent any external items from getting caught in the machine. Do not wear jewelry when operating the band sealer.

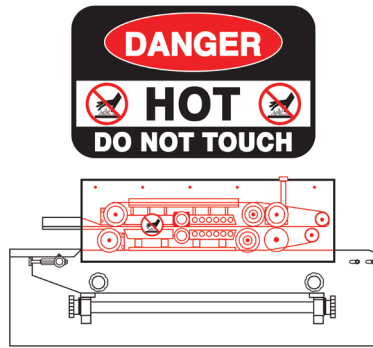

- ❖ While machine is operating do not touch the heating and/or cooling blocks. Blocks will be extremely hot and may burn your hands.



- ❖ While machine is in operation, do not place fingers, tools, or other foreign objects on or into the machine. Do not touch any moving parts while machine is operating. Fingers may get caught in between the gears /pinch points and cause significant injury.
- ❖ Thermoplastic bags and material are hand fed into the machine. Place bag on the guide and carefully feed the bag through the band sealer. Fingers may be placed on the guide but do not allow fingers to touch any of the moving parts on the band sealer.
- ❖ Use emergency stop to turn off machine should material/bags get jammed into the machine. Carefully pull material out of the band sealer. Do NOT use fingers to touch any part of the machine.
- ❖ The band sealer is not water resistant or water proof. Spraying down the machine will damage machine or cause electrical shock. Do not submerge the band sealer into water or liquid.
- ❖ Do not operate band sealer in a corrosive or humid environment.
- ❖ Always keep the machine clean, lubricated and in good working condition. Follow any maintenance and lubrication procedures outlined in this manual. Make sure unit is disconnected from power source before cleaning.
- ❖ NEVER use any accessories or parts from other manufacturers. Machine should not be altered or modified using parts that are not genuine authorized parts. Doing so will VOID YOUR WARRANTY.
- ❖ Never leave the band sealer unattended. Be safe, disconnect the band sealer from power source before leaving work area.
- ❖ Close supervision is necessary when any appliance is near children or persons with reduced physical, sensory or mental capabilities or lack of experience and knowledge . This sealer is NOT to be used by children or by persons with reduced physical, sensory or mental capabilities or lack of experience and knowledge.
- ❖ DO NOT use the band sealer outdoors.
- ❖ DO NOT use the band sealer while under the influence of drugs, medications or alcohol.

SAVE THESE INSTRUCTIONS - REFER TO THEM OFTEN AND USE THEM TO INSTRUCT OTHERS.

Introduction

Our band sealers are equipped with electronic temperature controllers and variable speed conveyors to seal all types of thermoplastic materials (PP, PE, stand up pouches, gusseted bags, moisture barrier bags, etc.). Seals are created using PTFE bands which maintain high seal quality and produce consistently strong, clean seals on all heat sealable bags. Because bags are placed on a conveyor system, the width of the bag does not matter. These versatile machines offer several adjustments which allow them to be used for a wide range of applications. These machines are used extensively in the food, medical, chemical, cosmetic, and electronic industries.

The FRM-1120C band sealer adopts dry ink coding designed to print date and lot codes at the seal line. Ink dries instantly upon contact with packaging materials and produces clear and legible characters. For FRM-1120C, the standard font size is 18PT which allows for two-line printing. An optional 10.5PT font size which allows for three-line printing can be purchased separately. Please ask your distributor for more information.

The FRS-1120W band sealer adopts hot stamp printing to print date and lot codes at the seal line. Hot stamp printing is similar to an analog printing press. Color ribbon printing provides a stronger adhesion print than dry ink coding and works best for humid environments.

The FRM-1120C / FRS-1120W are stand alone units with casters providing easy mobility for the band sealer. In addition, the sealer is equipped with a tilting mechanism which allows the conveyor to tilt up to 30 degrees, ideal for packaging liquids and grains.

Features of our Band Sealer

Your band sealer is equipped with a wide range of standard features and capabilities.

- ❖ Simple to use – minimal operator training
- ❖ Fast warm up time
- ❖ Unit feeds right to left
- ❖ Rust inhibiting stainless steel construction
- ❖ Equipped with bag entry guide for easy bag feeding and straight seals
- ❖ Industrial grade safety emergency stop switch
- ❖ 10amp protection power surge breaker
- ❖ Equipped with photo sensor for optimal printing precision
- ❖ Dry ink coder for printing characters at the seal line (FRM-1120C)
- ❖ Hot stamp printing coder for printing characters at the seal line (FRS-1120W)
- ❖ Wide seal (8mm) to assure airtight seal
- ❖ PTFE sealing belts
- ❖ Extended forced-air cooling system with extra wide cooling bars and 6 heat transfer orifices
- ❖ One pair of brass sealing bars
- ❖ Sealing method – constant heat
- ❖ Adjustable 2-way pulley system for optimal stability and embossing clarity

- ❖ Knurled pressure rolls with variable pressure adjustment
- ❖ PID digital temperature controller 0-300°C (572°F) with dual alphanumeric displays (target & current temperature)
- ❖ Motorized rubber conveyor with speed control
- ❖ Capable of speeds up to 394 inches/minute

How Does the Band Sealer Work?

Basic

Principles

FRM-1120C is easy to use. To seal, adjust temperature and place bag on conveyor

Our band sealers are comprised of a stainless steel frame, speed adjusting mechanism, sealing temperature control system and transmission system. Turning on the heat for the band sealer will cause a rapid rise in the temperature of the heating blocks. Required temperature and speed can be adjusted via the temperature controller and speed adjusting device. Plastic material to be sealed is

placed on the guide and conveyor. Conveyor will then take the material between the two heating blocks to fuse the material together. Material will then pass through the cooling blocks to allow the material to congeal. Finally, a photoelectric sensor will direct the dry ink coder to print a clear and legible print at the seal line.

The motor drives the sealing belts, drive belts and conveyor simultaneously.

Specifications

	FRM-1120C	FRS-1120W
	Dry Ink Coding	Hot Stamp Printing
Power	110V/60Hz	
Motor Power	100W	
Sealing Speed	0-394 inches/minutes	
Sealing Width	8mm	
Temperature Range	0-300°C (572°F)	
Conveyor Size	43" x 8"	
Max Conveyor Load	16.5lbs	
Printing Heating Power	40 x 2 (W)	50 x 2 (W)
Character Size	3x5x7mm / 18PT – 2 lines 2x3x7mm / 10.5PT – 3 lines (additional option available)	2x4x15mm
Printing Colors	Black, Blue, Green, Red, White, Yellow	Black, Blue, Red, White
Dimensions	43" x 24" x 41"	
Weight	187lbs (n.w.) / 275lbs (g.w.)	

Band Sealer Diagram

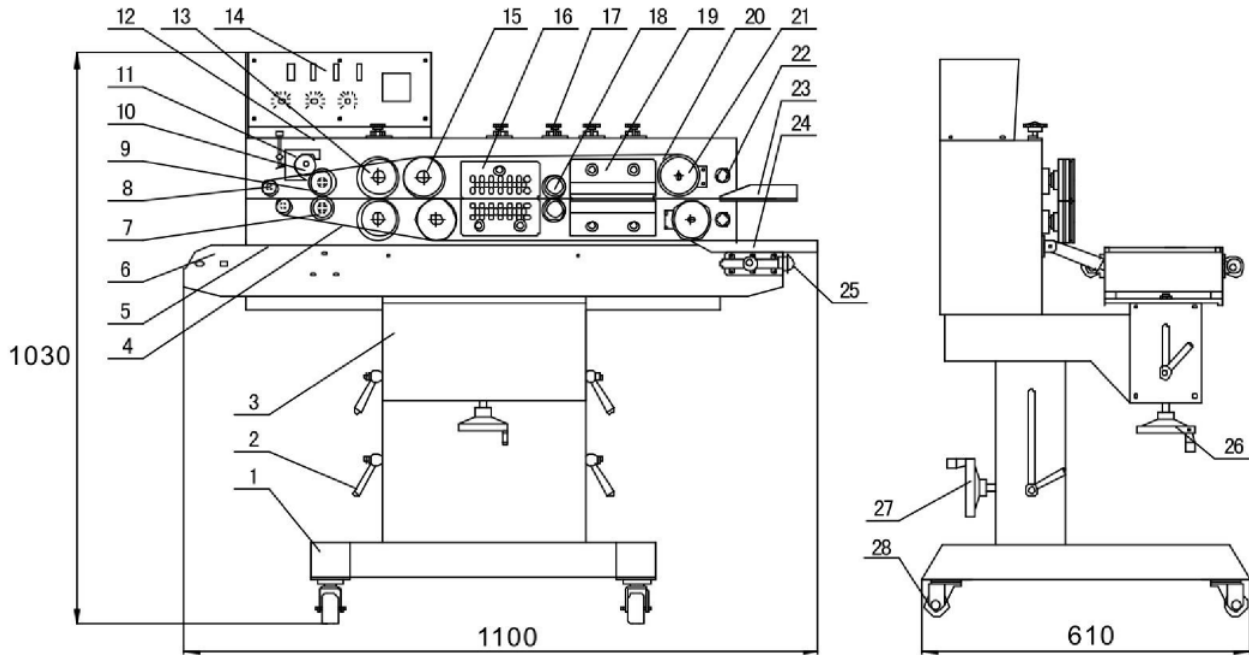

Figure 1. FRM-1120C (1) Pedestal, (2) Lock Handle, (3) Slide Block for Bracket, (4) Guide Belt, (5) Conveyor Belt, (6) Conveyor Table, (7) Silicone Wheel, (8) Guiding Wheel (small), (9) Printing Wheel, (10) Solid Ink Roller, (11) Ink Roller Heat Block, (12) Housing Case (13) Embossing Wheel (14) Control Panel (15) Driving Wheel, (16) Cooling Block, (17) Adjusting Knob, (18) Pressing Wheel, (19) Heating Block, (20) Sealing Belt, (21) Driven Wheel, (22) Cam Shaft, (23) Guide, (24) Work Table, (25) Adjusting Knob for Conveyor, (26) Lifting Hand Wheel of Conveyor Table, (27) Lifting Hand Wheel of Complete Unit, (28) Casters

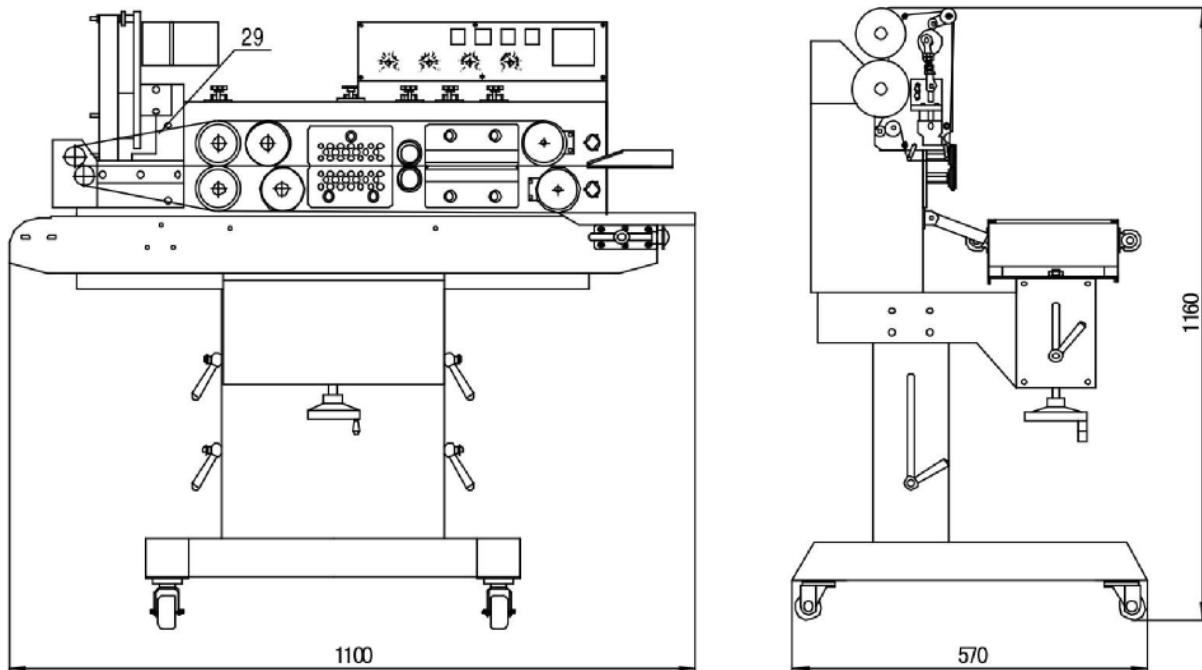
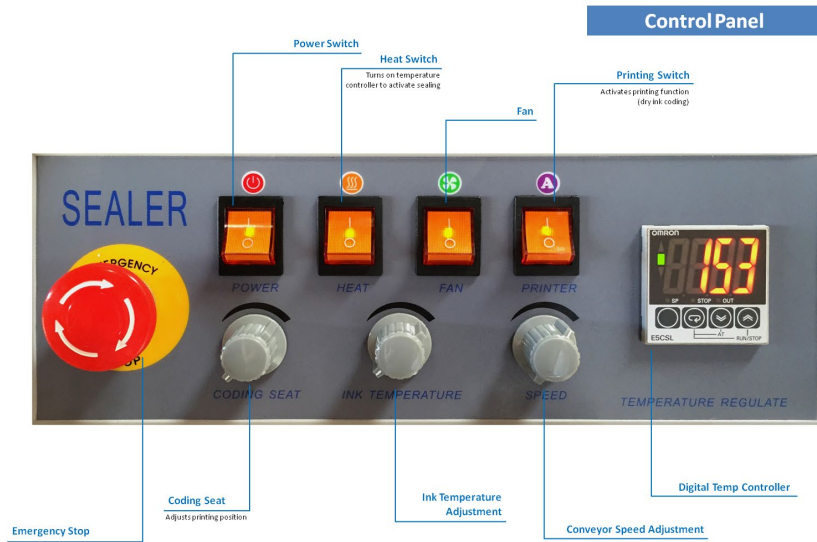
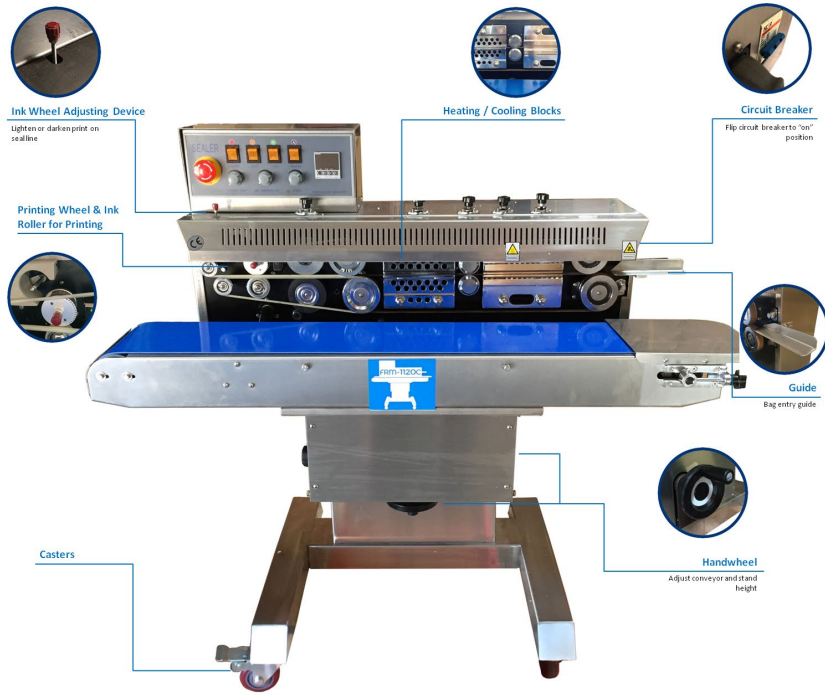

Figure 2. FRS-1120W Band Sealer (29) Hot Stamp Imprinter

Getting to Know your Band Sealer



Electrical Circuit Diagram

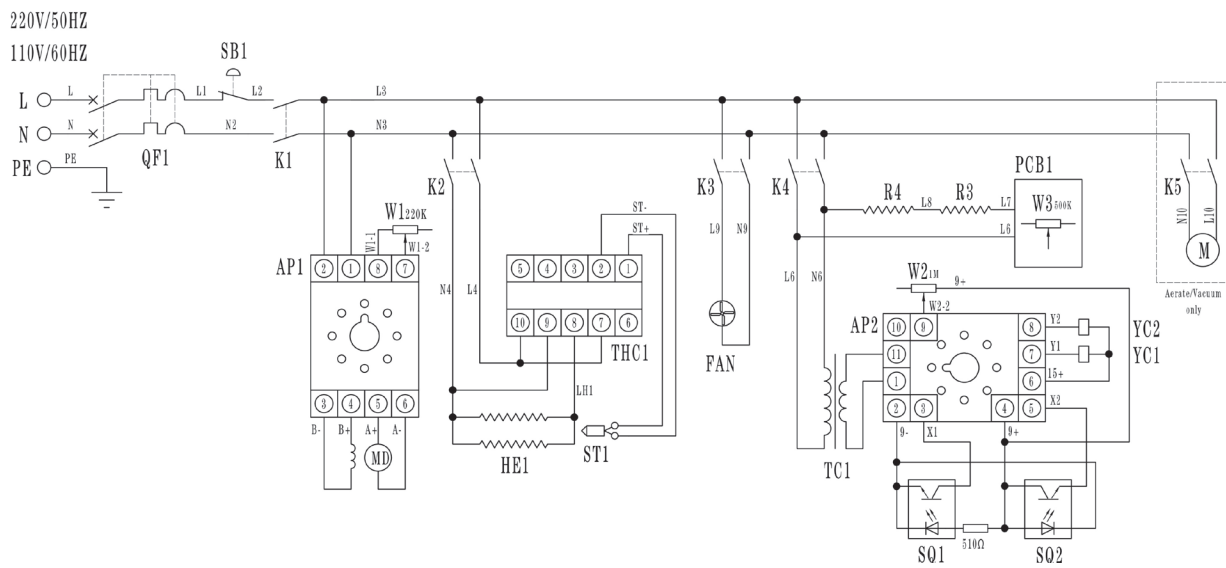

Figure 3. Electrical Circuit Diagram. (QF1) High Rupture Switch, (SB1) Emergency Stop Switch, (K1) Switch/Power, (K2) Switch/Heat, (K3) Switch/Fan, (K4) Switch/Printer, (K5) Switch/Aerating-Vacuum (W1) Speed-Regulating Potentiometer; (W2) Coding Position Potentiometer, (W3) Temperature-Regulating Potentiometer; (HE1) Heating Element of Sealing, (R3/R4) Heating Element of Ink Roller; (MD), Speed adjusting Motor; (M) Aerating/Vacuum, (FAN) Fan, (TC1) Transformer, (YC1) Electromagnetic Clutch, (YC2) Electromagnetic Brake, (SQ1) Groove Sensor, (SQ2) Photoelectric Sensor, (THC1) Temperature Controller, (ST1) Thermocouple, (AP1) Speed Adjusting PC Board, (AP2) Main Control PC Board, (PCB1) Temperature Adjusting PC Board

Installation

Important

Read this manual carefully, and make it available to everyone connected with the supervision, maintenance, or operation of this machine. Additional copies are available at your request. (Contact your distributor for this information.) Be very careful when operating, adjusting, or servicing this equipment. If in doubt, stop and obtain qualified help before proceeding.

Installation

Place the band sealer in the desired location with the required electrical power source available. (See power requirements.) Make certain that proper electrical wiring is provided to guard against low voltage. If the voltage is too low, the equipment will not function properly.

Finding the proper location is a most important function of the initial set-up. One must take several factors into consideration:

- ❖ Adequate power source
- ❖ Relationship to source of product
- ❖ Relationship to band sealer
- ❖ Relationship to any conveyors necessary to transport finished product
- ❖ Convenience of operator

1. Your new FRM-1120C band sealer comes packaged in a heavy duty crate to protect it. If your machine does not arrive in this condition, write on shipping paperwork that outside of box is damaged. Concealed damage may have occurred.
2. Remove the nails.

FRM-1120C INSTRUCTION MANUAL



Figure 4. FRM-1120C Crate

3. Remove the protective plastic covering the machine.
4. Remove bolts holding machine to crate.



Figure 5. Bolts locking FRM-1120C to crate.

5. Carefully check the contents against the spare parts list in the toolbox (see Spare Parts List on page 54). Once you have determined that all of the parts have arrived in good order set up can proceed. If any parts are missing or appear to be damaged, please notify your distributor or Sealer Sales AND your freight company at once.

Operating your Band Sealer

Operation Set-up

1. Our machines are equipped with a three-prong grounded plug. Make sure the plug is well-connected in the socket to ensure safe operation.
2. Make sure the circuit breaker is in the “ON” position. (Levers pointing up)
3. First time operation. Allow the machine to pre-heat by running at a low temperature for a few minutes. This would apply if the machine has not been in operation for a long time. The machine can sometimes be damp from storage or shipment and running at a low temperature will dry out any residual moisture.
4. Adjust the conveyor position forwards or backwards. Loosen the two screws at the bottom of the conveyor table. Move out the conveyor table to the suitable position, then fasten the screws. Refer to **Figure 6**.

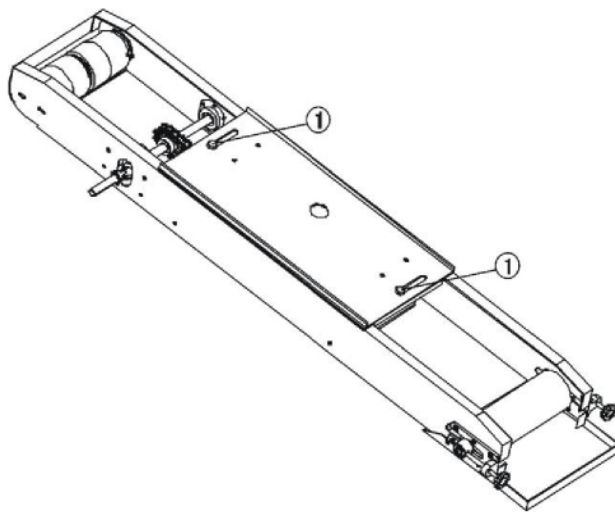

Figure 6.

5. Adjust the guide to adjust seal width and position of seal line on your material.

Operation



Figure 7. Control Panel of FRM-1120C

1. Our machines are equipped with a three-prong grounded plug. Make sure the plug is well-connected in the socket to ensure safe operation.
2. Make sure the circuit breaker is in the “ON” position. (Levers pointing up)
3. Turn Power, Heat (Seal), Fan, and Printer switches to the “On” position. Belts and conveyor will begin to move simultaneously.
4. Adjust the conveyor speed.
5. Adjust the temperature controller to the temperature desired to seal your material. Temperature settings will vary based on bag material and thickness. If you are unsure what temperature setting to use, we recommend starting at a low temperature (150°C) and gradually increase to a temperature that will seal your material. We highly discourage sealing material at a temperature above 200°C. **Please note: Temperature will be in Celsius, not Fahrenheit.** The temperature controller cannot be displayed in Fahrenheit.





The PV value is the actual temperature and the SV value is the desired temperature setting. The SV value can be viewed by pressing the  button.



Figure 8. FRM-1120C Temperature Controller

- a. To set the temperature, press the  button. The SV temperature will be displayed. The SP light will be on to show the SV temperature.
 - b. Press the  and  button to change temperature setting.
 - c. Press the  button to save the temperature settings.
 - d. Wait until the PV temperature matches the SV temperature which should take approximately 5-10 minutes.
 - e. Check our YouTube channel (<https://www.youtube.com/user/sealersales>) for a video demo.
 - f. **Please note:** Temperature will be in **Celsius**, not Fahrenheit. Do not attempt to make additional adjustments to the temperature controller besides the temperature. The temperature controller CANNOT be displayed in Fahrenheit and is ALWAYS in Celsius. **Please do not set the temperature controller above 200°C.** Please contact your local distributor if you need assistance.
6. Adjust the pressure knob (**Figure 34 , Item #71**) on your band sealer depending on the thickness of your bag material.
 7. Place material on the guide (**Figure 36, Item #28**) and allow the band sealer to pull your material through. Make sure your material is flat on the guide. While the material is moving through the band sealer, do not push or pull the material as this will cause irregular sealing.
 8. If the sealing belt is running off the guide wheels, make adjustments to the screws that are found on the driven wheel seat (**Figure 9, Item #1 & 2**)

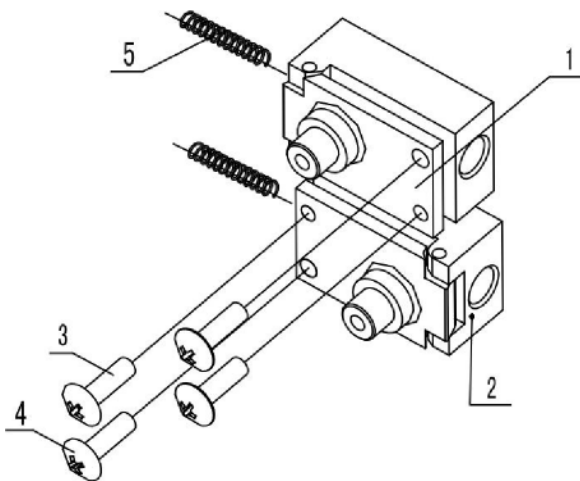

Figure 9. (1) Driven Wheel Seat (Adjusting Block), (2) Driven Wheel Seat (Adjusting Block), (3)/(4) Adjusting Screws, (5) Springs

9. Emergency Stop – Press the emergency stop to turn off the machine. In order to restart the machine, you must release the emergency stop by turning the knob 120° clockwise.
10. To shut down, turn off the heater switch and allow the temperature of the machine to drop before turning off the power and fan switches. *Following this shut down procedure will significantly prolong the life of machine and sealing belts.*

Sealing Optimization

1. Sealing performance can be adjusted with the sealing temperature and sealing speed. The higher the speed the less exposure the material to heating blocks and therefore a higher temperature will be required to seal the material.
2. Try a variety of different sealing temperatures and conveyor speeds to get the optimal seal for your material.

Printing Operation - FRM-1120C

FRM-1120C is equipped with a dry ink coding feature capable of printing characters at the seal line. Ink dries instantly upon contact with packaging materials and produces clear and legible letters/numbers. Standard font size is 18PT which allows for two-line printing up to 20 characters per line. Optional print wheel which allows for 40 characters per line is available to be purchased separately. In addition, we also carry 10.5PT font size which allows for three-line printing can also be purchased separately. Ask your distributor for more details. Check our YouTube channel (<https://www.youtube.com/user/sealersales>) for a video demo.



Figure 10. Standard font size - 18PT

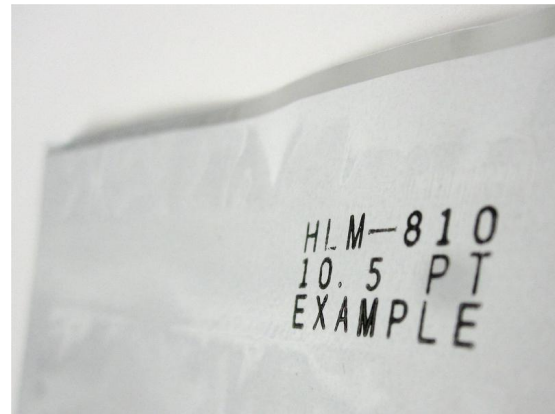

Figure 11. Optional 10.5PT font size available for purchase

1. **Removing Print Wheel.** To remove the printing wheel from the base, push the red handle in and turn clockwise until you feel the handle unlock. (See [Figure 12](#) and [Figure 13](#) for locked and unlocked positions). You may need to turn the wheel a few times until the red handle unlocks and pops out of its locked position.

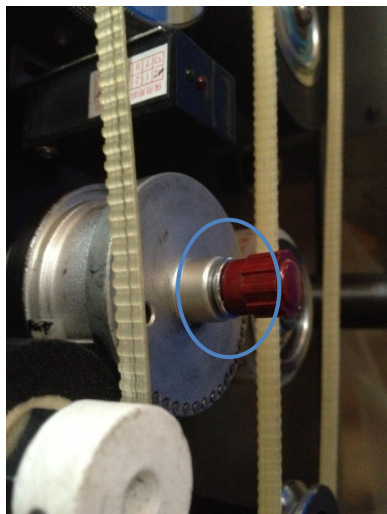

Figure 12. Locked Handle Position

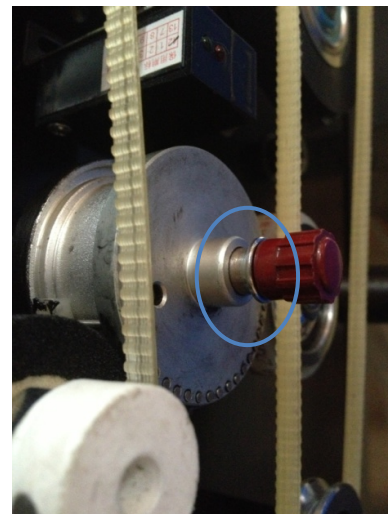

Figure 13. Unlocked Handle Position

- 2. Installing Types/Characters on Print Wheel.** Place selected characters in the grooves of the printing wheel. Be sure to insert the characters from right to left to ensure actual imprint prints correctly on your packaging material. Once completed, insert the silicone pin at the top of the printing wheel to hold the characters in place.



Figure 14. Place characters from right to left.



Figure 15. Place silicone pin to lock characters in place.

- 3. Installing the Print Wheel.** To insert the spring-loaded print wheel into the print wheel base, ensure that the pin on the printing wheel is aligned with the notch of the print wheel base. Gently insert the print wheel into the base. Lock the print wheel by pushing the red handle in until you feel the handle lock into place.



Figure 16. Ensure two holes and pins line up with the base

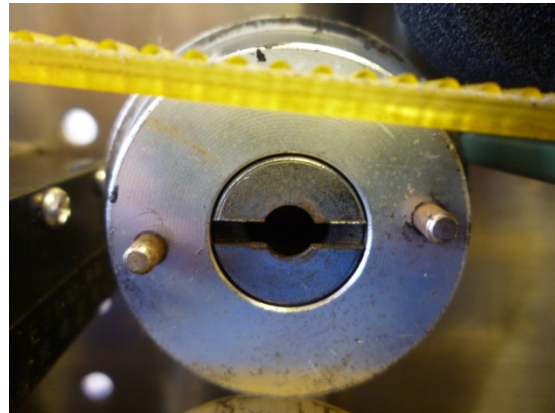

Figure 17. Ensure two holes and pins line up with the base

4. **Install Ink Roller into the Ink Roller Holder.** Remove the metal ring found on the ink roller holder using an allen wrench. Place the ink roller onto the ink roller holder and place the metal ring back on the ink roller holder to hold the ink roller in place. Please note that for 30mm wide ink rollers, the metal ring will not be used.



Figure 18. Remove metal ring found on the ink roller holder



Figure 19. Ink roller installed on ink roller holder

5. **Insert Ink Roller in the Ink Wheel Heating Block.** When inserting the ink roller, ensure the ink roller lines up with the type on the printing wheel. If the ink roller is pushed in too far, the printing wheel will not print correctly. *Note: Do not allow the ink roller to heat continuously when machine is not in use as heating block may melt the ink roller.*

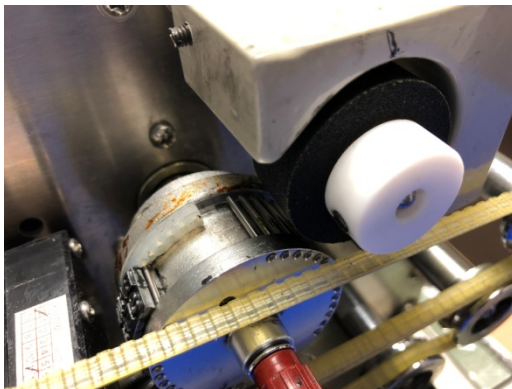

Figure 20. Correct Ink Roller Position

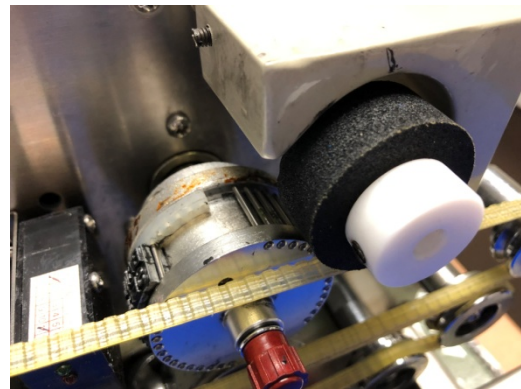

Figure 21. Incorrect Ink Roller Position

Test the ink roller position relative to the printing wheel. Place your finger under the photoelectric sensor. The sensor light will turn green and allow the printing wheel to rotate.

6. **Make Adjustments to Ink Wheel Adjusting Device.** As the print wheel rotates, check that the printing wheel makes contact with the ink roller. Make adjustments using the ink wheel adjusting device (Figure 22, Item #5) if necessary. Turning the adjusting screw clockwise will move the ink roller away from the print wheel and turning the adjusting screw counterclockwise will move the ink roller closer to the print wheel.

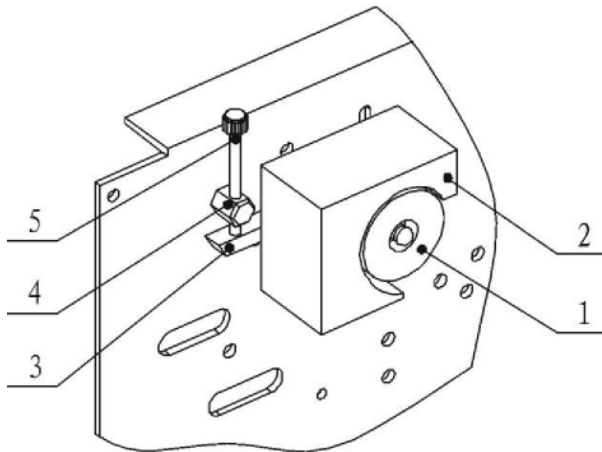

Figure 22. (1) Ink Roller, (2) Ink Roller Heating Block, (3) Swing Pole, (4) Adjusting Strut, (5) Ink Wheel Adjusting Device

7. **Make Adjustments Between Printing Wheel and Silicone Wheel.** The typesets/characters on the printwheel should only touch the silicone wheel during the printing process. The characters should not touch the silicone wheel at any other time. If the band sealer is used to seal relatively thicker materials, the screw (Figure 23, Item #4) should be loosened. Rotate the eccentric sleeve (Figure 23, Item #3) to ensure the characters/typesets slightly touch the silicone wheel's surface. Refasten the screw after making adjustments.

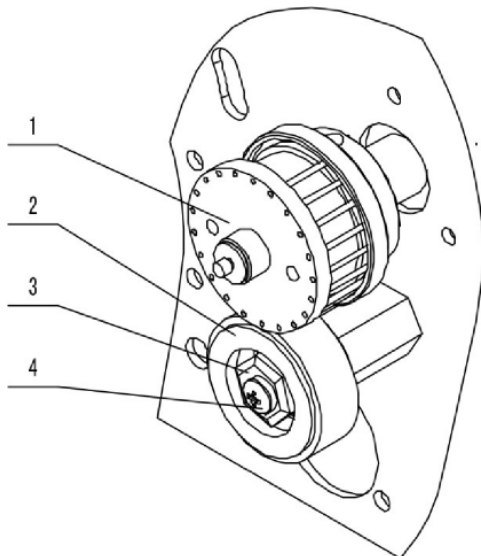

Figure 23. (1) Printing Wheel, (2) Silicone Wheel, (3) Eccentric Sleeve, (4) Screw

8. **Setting Printing Temperature.** We recommend setting the ink temperature on the higher end. Allow 5-10 minutes for the ink heating block and ink roller to reach the correct temperature. *Note: If band sealer is not in use right away, do not leave ink roller in the unit while temperature is on. This may result in the ink roller melting and producing messy print.*
9. **Adjust Printing Position.** The coding seat knob determines printing position on your material. For example, if you want to print on the left side of your bag, turn the coding seat to its lowest

setting (or counterclockwise). If you want to print on the right side of the bag, turn the coding seat to a higher setting (or clockwise).

Printing Optimization

1. Print quality will be determined by the degree of ink melting, distance between the ink roller and printing wheel and distance between the silicone wheel and printing wheel.
2. Over time, decrease the gap between the ink roller and printing wheel.
3. A newer ink roller will require a lower temperature vs. an older ink roller. Make adjustments to ink temperature as necessary.
4. Ensure there is adequate pressure on the silicone wheel (**Part #BS-57A**) by the printing wheel. We suggest using factory default settings before making any adjustments. Adjustments may be needed based on material thickness.
5. If the printing wheel rotates and there is no thermoplastic material running through the band sealer, excess ink will rub off on the silicone wheel. Clean the silicone wheel with a shop cloth and silicone spray to remove any excess ink.
6. *Remove the ink roller from unit until sealer is ready for use. If ink roller is left in the machine while not in use, this may result in melting of the ink roller and messy print. To clean, wipe down belts, silicone wheel, and other parts with silicone spray and cloth.*

Printing Operation - FRS-1120W

FRS-112W is equipped with a hot stamp ribbon printer. The printer works much like an analog printing press. Types are loaded into the imprinter then heated. An inked printing ribbon sits between the type and material to be printed. The heated type presses onto the ribbon, melting the ink onto the material. A spring biased dancer assembly having a idler roller maintains a tension on the inked print ribbon as the inked print ribbon is transferred from a supply reel to a rewind reel. To change the code of the hot stamp, types can be easily replaced.



Figure 24. Type Example - FRS-1120W

1. Determining the correct position for printing on your bag will require some trial and error. Adjust the Speed, Coarse Tuning, and Fine Tuning knobs to determine the optimal printing location on your bag.



Each number dial turn moves the print approximately 1" – 1½" to the right

Each number dial turn moves the print approximately 1/8" to the right

Figure 25. FRS-1120W Control Panel

2. To install the hot stamp ribbon, web the imprinter per diagram below ([Figure 26](#)). Be sure that the dull side (pigment) of the tape faces away from printing head and toward the base of the imprinter. To web the ribbon through the ribbon press wheel, pull the handle upwards to release the ribbon press wheel. Lock the ribbon to the collect wheel by using a piece of scotch tape to adhere the ribbon to the collect wheel.

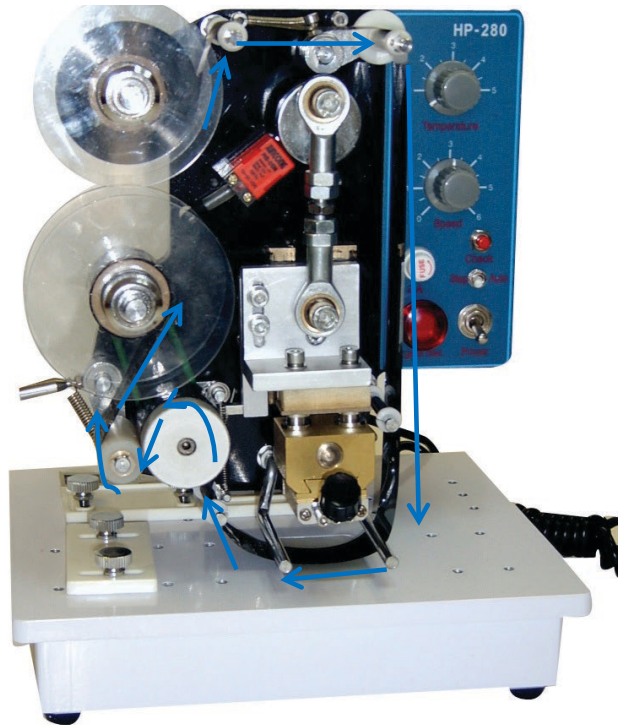

Figure 26. Ribbon Webbing Guide

3. Insert the printing head/type holder in the printing block. To lock the printing head, press the handle on the printing head inward and turn clockwise about 90 degrees. When locked, you should not be able to pull the printing head out of the printing block.
4. If temperature is left on while imprinter is not in use, we suggest turning the ribbon collect wheel a few turns so that ribbon exposed to the heat of the printing block is moved into the ribbon collect wheel. This will prevent ribbon breakage.

Imprinter Adjustments

Best results in hot stamp imprinting depends on correct temperature, pressure, and stroke speed. Different materials may require adjusting any of these, as follows:

1. **Temperature Adjustment.** Turn the temperature knob to the appropriate temperature for the material to be printed. Turning the knob clockwise will cause the temperature to rise and turning the temperature counterclockwise will cause the temperature to lower. Wait approximately 15-20 minutes for imprinter to reach set temperature.
2. **Pressure Adjustment.** Normal printing pressures vary with the printing material. Pressure should be kept just high enough to obtain good results. Too much pressure causes excessive wear on type and silicone rubber pad. If pressure is too high, the ribbon may break and printed materials may be melted through. If pressure is too low, the printed characters will be illegible.

The connection pole can be adjusted up or down to accommodate different types of material and varying degrees of print darkness. To adjust the length of the connection pole, release either of the two nuts located on the connection pole. Turning the nuts clockwise will cause the

connection pole to lengthen. Turning the nuts counterclockwise will cause the connection pole to shorten.



Adjust either of the two nuts located on the connection pole.

Figure 27. To adjust the length of the connection pole, release either of the two nuts located on the connection pole. Turning the nuts clockwise will cause the connection pole to lengthen. Turning the nuts counterclockwise will cause the connection pole to shorten.

3. **Ribbon Step Distance Adjustment.** The step distance is the amount of tape pulled through by each printing stroke. If the step distance is higher, more ribbon will be consumed during print. This distance is controlled by the bolt located at the back of the machine. Loosen the butterfly-shaped nut found on the bolt. Moving the bolt upwards will reduce the step distance and moving the bolt downwards will increase the step distance. Once the optimal step distance is acquired, tighten the butterfly-shaped nut. The tape should advance just enough to present a new surface on each impression.

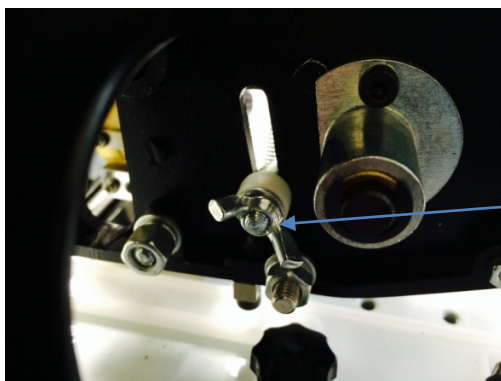

Loosen butterfly-shaped nut and adjust the bolt up or down.

Figure 28. Ribbon Step Distance Adjustment. Loosen the butterfly-shaped nut found on the bolt. Moving the bolt upwards will reduce the step distance and moving the bolt downwards will increase the step distance.

Changing Type

Typesets are easily changed but *please use caution as the printing head/typeset holder will be extremely hot when taken out of the imprinter.* Using an allen wrench, loosen the set screws (Part# HP-280-58) to release the typesets. Insert new types into the printing head/typeset holder and tighten set screw to ensure types do not fall out when inserted into the printing block. Additional types may be ordered as needed. Please ask your distributor for more details.

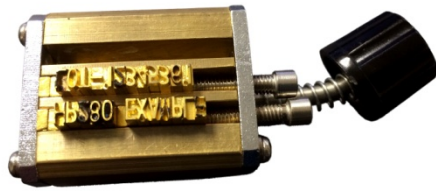

Figure 29. Printing Head / Typeset Holder with typesets

Maintenance

The following maintenance procedures should be followed to ensure the longevity of your FRM-1120C band sealer.

Inspection and Cleaning

1. Inspect your machine daily.
2. Check if there is any foreign matter or dirt adhering to the band sealer.
3. To clean your band sealer, wipe down your sealer with silicone spray and a shop cloth. Do not apply silicone directly to your sealer. Definitely DO NOT wash down your machine with water.

Sealing and Drive Belts

1. Check and replace the belts as necessary. Both the sealing and drive belts are consumable items. Replace sealing belts when there are burn marks or if the belts become hard and brittle. Replace drive belts when the belts break or become badly cracked.
2. To change out the belts, make sure the machine is turned off.
3. Remove the safety cover.
4. Remove the two drive belts.
5. To remove the sealing belts, push on the adjustment blocks (**Figure 34, Item #28/34**) and the sealing belts should easily slip off.
6. Put new sealing and/or drive belts back on the machine. Test the machine, making adjustments as necessary.
7. Replace the safety cover.
8. Check our YouTube channel (<https://www.youtube.com/user/sealersales>) for a video demo.

Turbocase Maintenance

1. Remove dust and clean motor at regular intervals. Avoid contact with alcohol, gasoline and benzene chemicals.
2. The turbocase should be oiled as needed with 50g 20# oil by:
 - a. Remove the back cover.
 - b. Locate the turbocase and unscrew the cap. Replenish any depleted gear oil with 50g 20# oil.
3. The motor brush (**Part #BS-29A**) is designed to be used 2,500 hours continuously. Replace carbon brush at regular intervals.

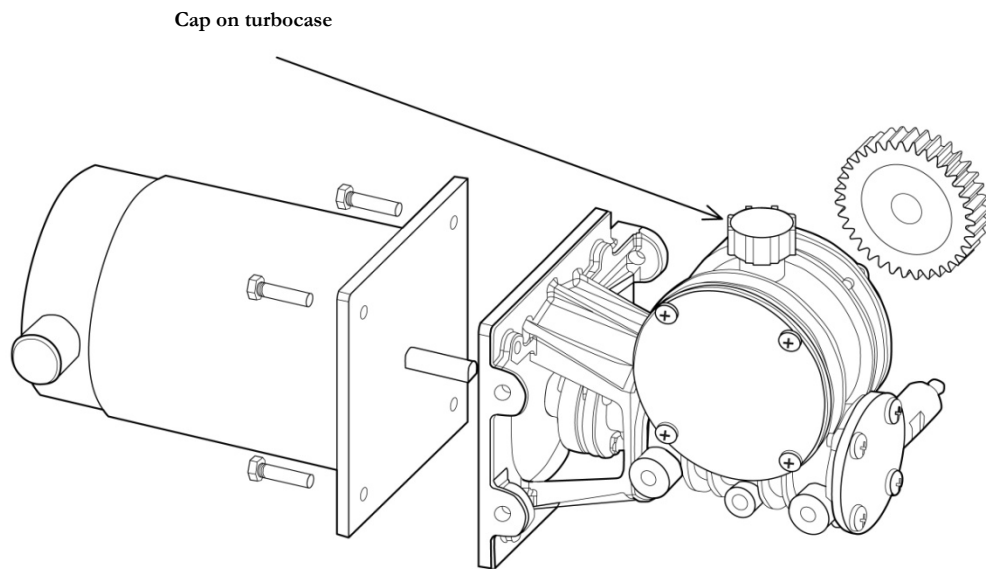

Figure 30. Turbocase cap

Printing Maintenance

FRM-1120C band sealers are equipped with an ink temperature potentiometer which is attached to a PC Board. This part controls the temperature that is transmitted to both the ink heating block as well as the printing wheel. The part is located behind the ink temperature knob. **(Figure 40, Item #12)** You should change the ink temperature potentiometer w/ PC Board when both ink heating block and printing wheel on your band sealer are not achieving optimal heat temperatures.

1. Turn off and unplug your band sealer.
2. Remove ink temperature knob from potentiometer and remove the washer that holds the ink temperature potentiometer on the panel.



Figure 31. Remove Ink Temperature Knob



Figure 32. Remove Washer Holding Ink Temperature Potentiometer

3. Remove the band sealer display panel. There should be six screws to remove.
4. Unplug the ink temperature potentiometer and plug in a new ink temperature potentiometer. Make sure the part is plugged in properly and tight.

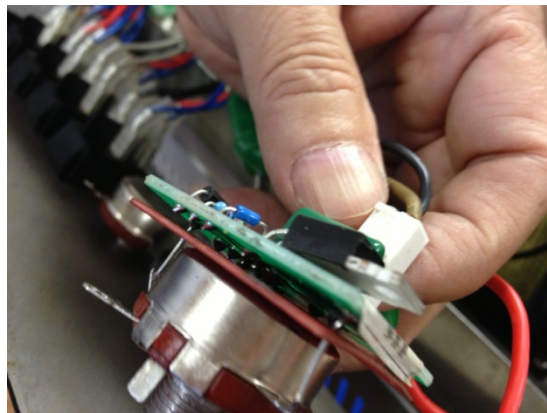

Figure 33. Unplug Ink Temperature Potentiometer w/ PC Board and Replace with a New Ink Temperature Potentiometer w/ PC Board

FRM-1120C Parts Diagram

To order spare parts, please use diagram and part #s below:

Figure 34 – Spare Parts Diagram Overview

Figure 36 – Heating / Cooling Blocks and Dry Ink Coding

Figure 38 – Conveyor Table

Figure 40 – Controller Box

Figure 43 – Sealer Rack

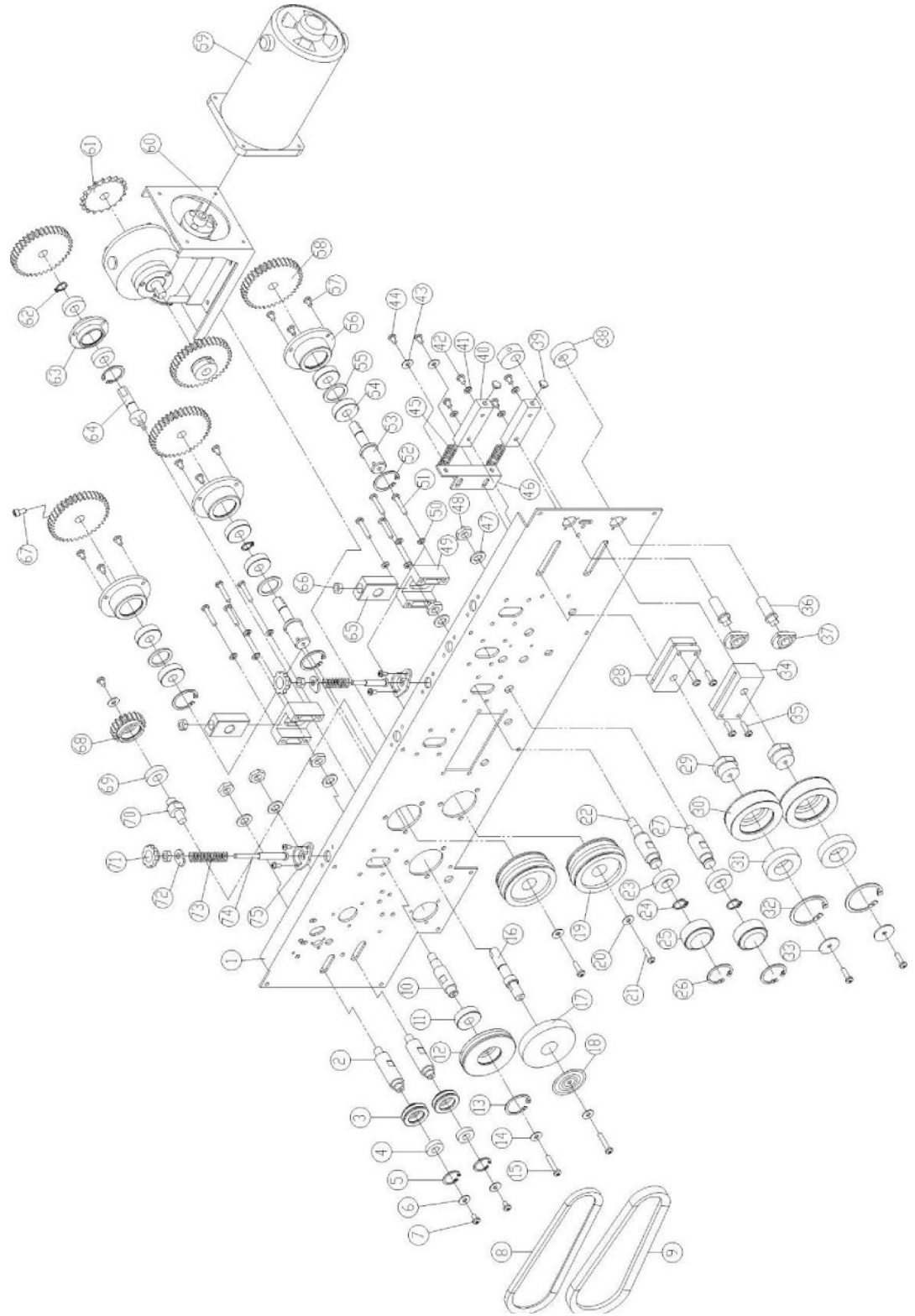

Figure 34. FRM-1120C Spare Parts Diagram Overview

Figure 35. FRM-120C Spare Parts Diagram Overview

Item	Part #	Quantity	Description	Reference	Comments
1		1	bottom board	106042	
2	FRM-1120C-6A-2	2	small pulley shaft	106002	
3	FRM-1120C-6A	2	small pulley	106003	Includes #3-5
4	FRM-1120C-6A	2	bearing (626)	GB/T276-1994	Includes #3-5
5	FRM-1120C-6A	2	circlip for hole	GB/T893.1-1986	Includes #3-5
6	Washer-M5x16	2	flat washer	GB/97.1-2002	
7	Screw-M4x8	2	screw	GB/T818-2000	M4x8
8	FRM-1120C-26	1	guiding belt (678×4.5×3.5) (65°)	910803	
9	FRM-1120C-26	1	guiding belt (678×4.5×3.5) (65°)	910803	
10		1	embossing wheel shaft	106006	
11	FRM-1120C-3A	1	bearing (6201)	GB/T276-1994	Includes #11-13
12	FRM-1120C-3A	1	embossing wheel	106007	Includes #11-13
13	FRM-1120C-3A	1	circlip for hole	GB/T893.1-1986	Includes #11-13
14	Washer-M5x16	1	flat washer	GB/T97.1-2002	M5x16
15	Screw-M4x8	1	screw	GB/T818-2000	M4x8
16		1	silicone wheel shaft	106011	
17	FRM-1120C-2	1	silicone wheel assembly	106010	
18		1	silicone wheel cover		
19	FRM-1120C-6	2	driving wheel	106012	
20	Washer-M5x28	2	flat washer		M5x28
21	Screw-M4x8	2	screw	GB/T818-2000	
22	FRM-1120C-21-22-26	1	upper pressing wheel shaft	106023	Includes #22-25
23	FRM-1120C-21-22-26	2	bearing (16002)	GB/T276-1994	Includes #22-25
24	FRM-1120C-21-22-26	2	circlip for shaft	GB/T894.1-1986	Includes #22-25
25	FRM-1120C-21-22-26	2	pressing wheel	106025	Includes #22-25
26	FRM-1120C-21-22-26	2	circlip for hole	GB/T893.1-1986	
27	FRM-1120C-21-27	1	lower pressing wheel shaft	106024	Includes #23-27
28	FRM-1120C-13	1	upper driven wheel seat (adjusting block)	106026	
29	FRM-1120C-12a	2	driven wheel shaft	106030	
30	FRM-1120C-12	2	driven wheel	106029	Includes #30-32
31	FRM-1120C-12	2	bearing (6005)	GB/T276-1991	Includes #30-32
32	FRM-1120C-12	2	circlip for hole	GB/T893.1-1986	Includes #30-32
33	Washer-M5x28	2	washer		M5x28
34	FRM-1120C-13	1	lower driven wheel seat (adjusting block)	106026	
35	Screw-M4x8	4	screw	GB/T818-2000	
36	FRM-1120C-13-36	2	cam shaft	11511011104	
37		2	cam shaft seat	106033	

FRM-1120C INSTRUCTION MANUAL

Item	Part #	Quantity	Description	Reference	Comments
38	FRM-1120C-13-38	2	cam	11511011106	
39	Screw-M4x8	2	screw	GB/T818-2000	
40	FRM-1120C-13-40	2	pressing plate for adjusting block	11511011107	
41	FRM-1120C-13-41	4	spacing ring of pressing plate	11511011108	
42	Screw-M4x8	4	screw	GB/T818-2000	
43	WasherM5x16	4	flat washer	GB/T97.1-2002	
44	Screw-M4x8	4	screw	GB/T818-2000	
45	FRM-1120C-13A	2	spring		
46		1	spring seat	106034	
47	Washer-M5x16	2	flat washer	GB/97.1-2002	
48		2	hexagonal nut	GB/T41-2000	
49	FRM-1120C-28-49	2	single slide block seat	106004	
50	Washer-M5x16	8	flat washer	GB/97.1-2002	
51	Screw-M4x8	8	screw	GB/T818-2000	
52	FRM-1120C-6-50-56	3	circlip for hole	GB/T893.1-1986	Includes #52-56
53	FRM-1120C-6-50-56	2	driving wheel shaft	106013	Includes #52-56
54	FRM-1120C-6-50-56	6	bearing (6201)	GB/T276-1994	Includes #52-56
55	FRM-1120C-6-50-56	2	spacing ring of bearing	106009	Includes #52-56
56	FRM-1120C-6-50-56	3	bearing seat	106008	Includes #52-56
57	Screw-M4x8	9	screw	GB/T818-2000	
58	FRM-1120C-35B	5	gear	106014	
59	FRM-1120C-29	1	motor 110V/100W		
	BS-29A	2	motor brush		Not shown
60	FRM-1120C-30	1	worm-gear case assembly	106084	determine gen 1.0 or 2.0
61	FRM-1120C-30-61	1	driving sprocket		
62	Circlip-T894.1-1986	3	circlip for shaft	GB/T894.1-1986	
63		1	bearing seat for connecting shaft	105013	
64		1	connecting shaft		
65	FRM-1120C-28-65	2	slide block	106005	
66	FRM-1120C-28-66	2	spring seat for slide block	106038	
67		5	socket cap screw	GB/T70.1-2000	
68	BS-35-68	1	medium gear	106040	
69		1	bearing (6101)	GB/T276-1994	
70		1	medium gear shaft	106041	
71	FRM-1120C-28A, 28B, or 28C	2	adjusting knob		A = 65mm, B = 77mm, C = 92mm
72	FRM-1120C-28A, 28B, or 28C	2	adjusting screw for slide block	106036	A = 65mm, B = 77mm, C = 92mm
73		2	spring for slide block		
74	FRM-1120C-28A, 28B, or 28C	2	adjusting double-screw bolt for slide block	106037	A = 65mm, B = 77mm, C = 92mm
75	FRM-1120C-28D	2	adjusting seat for slide block	106035	

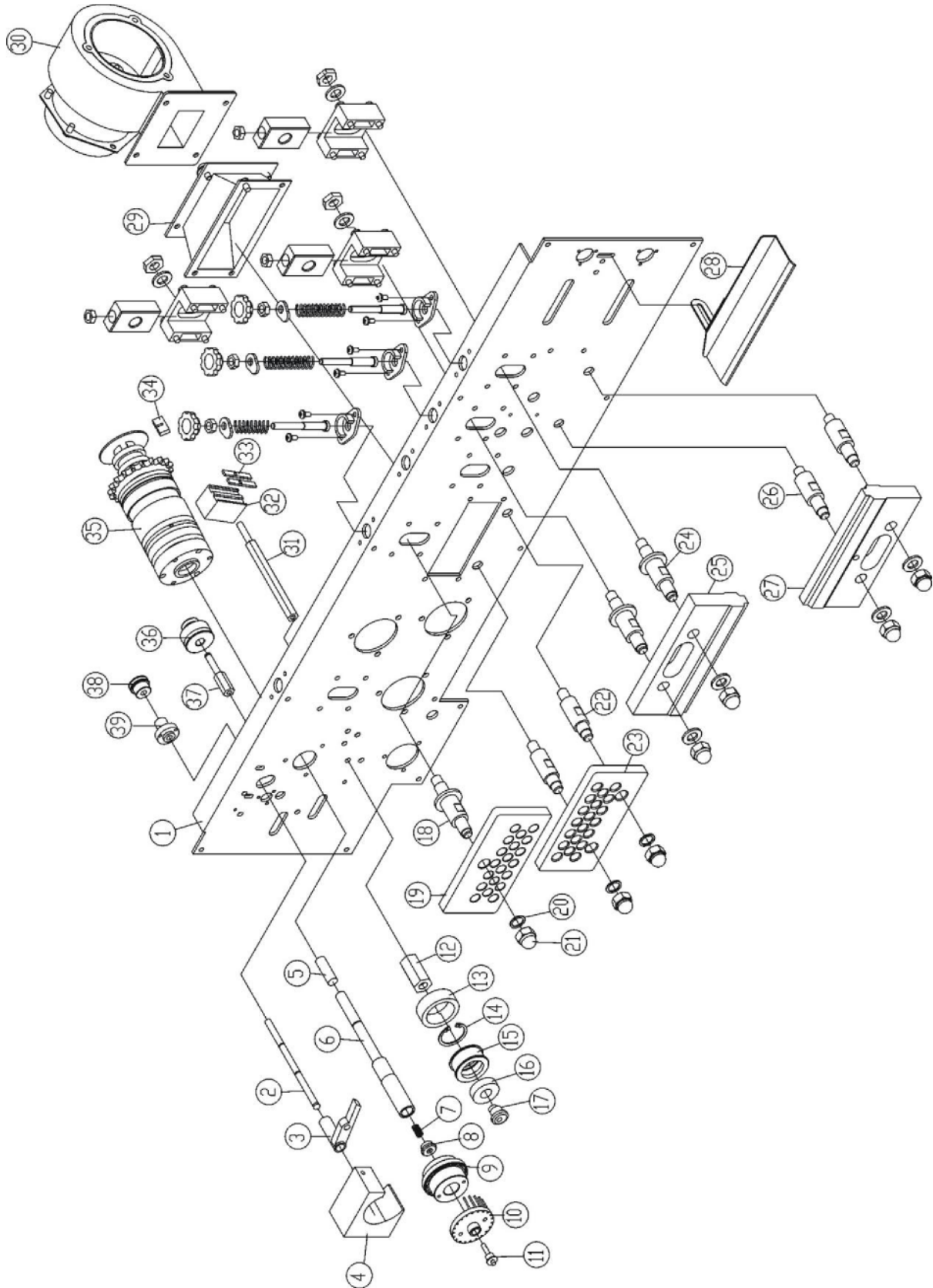

Figure 36. FRM-1120C Heating / Cooling Blocks and Dry Ink Coding

Figure 37. FRM-1120C Heating / Cooling Blocks and Dry Ink Coding
 (Last Updated: 07/06/21)

Item #	Part #	Quantity	Description	Reference	Comments
1		1	bottom board	106042	
2	BS-46	1	ink roller shaft	105036	
3	BS-62E-FRM	1	swing pole of ink roller	201007	
4	FRM-1120C-47	1	heating block of ink roller	201002	
5	BS-48C	1	heating pipe 110v/40w	921301	
6		1	printing wheel shaft	106071	
7	BS-48-7	1	spring of holding latch on printing wheel		
8	BS-48-8	1	cover for printing wheel shaft	201015	
9	BS-48B	1	printing wheel	201013	
10	BS-48A	1	printing wheel cover	201014	Includes #10, #11
11	BS-48A	1	holding latch for printing wheel	201016	Includes #10, #11
12		1	printing-silicone wheel shaft	201010	
13	BS-57A	1	silicone ring	910107	
14	BS-57	1	circlip for hole	GB/T893.1-1986	Includes #14-16
15	BS-57	1	core of silicone wheel	201011	Includes #14-16
16	BS-57	1	bearing	GB/T276-1994	Includes #14-16
17	BS-57B	1	eccentric sleeve	201012	
18	FRM-1120C-8-18	1	upper cooling block shaft	11511010502	
19	FRM-1120C-8	2	upper cooling block	11511010503 /11511010601	Includes #19, #23, sold as pair
20	Washer-M10x20	7	flat washer	GB/97.1-2002	
21	Nut-BS-CapNut	7	cap nut	GB/923-1988	
22	FRM-1120C-8-22	1	lower cooling block shaft	11511010602	
23	FRM-1120C-8	1	lower cooling block	11511010503 /11511010601	Includes #19, #23, sold as pair
24	FRM-1120C-9-24	2	upper heating block shaft	11511010902	
25	FRM-1120C-9A-SS	1	upper heating block	11511010901 / 11511011002	Includes #25, #27, sold as pair
26	FRM-1120C-9-26	2	lower heating block shaft	11511011001	
27	FRM-1120C-9A-SS	1	lower heating block	11511010901 / 11511011002	Includes #25, #27, sold as pair
28	FRM-1120C-44	1	feed opening	101035	
29		1	wind catcher	106058	
30	FRM-1120C-32	1	fan		
31	BS-64B	1	support for brush	106073	
32	BS-64A	1	carbon brush holder	920423	
33	BS-64C	2	pressing plate of brush	201009	
	BS-64	2	carbon brush		
34	BS-65	1	groove sensor		
35	BS-139-FRM-1120C	1	electromagnetic clutch assembly	A10501	
36	BS-54B	1	middle pulley	105032	
37	BS-54B-35	1	middle pulley shaft	105035	
38	BS-54C-34	1	ink roller shaft pulley	105041	
39	BS-54C	1	seat for ink roller swing pole shaft	201006	

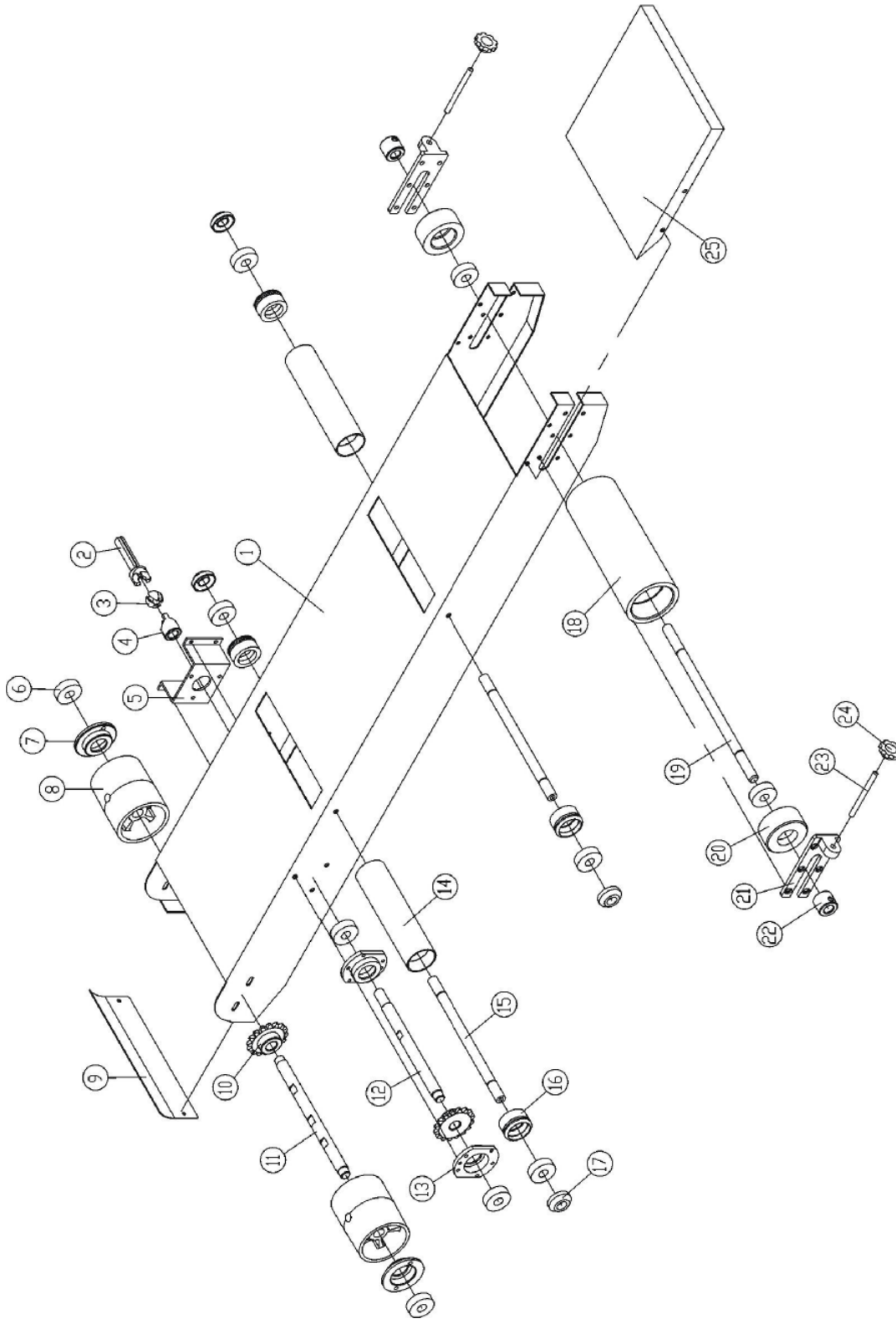

Figure 38. FRM-1120C Conveyor Table

Figure 39. FRM-1120C Conveyor Table

Item #	Part #	Quantity	Description	Reference	Comments
1		1	conveyor table		
2	FRM-1120C-41	1	adjusting shaft		Includes #2-5,#12-13
3	FRM-1120C-41	1	connecting ball		Includes #2-5,#12-13
4	FRM-1120C-41	1	connecting sleeve		Includes #2-5,#12-13
5	FRM-1120C-41	1	base plate for middle shaft	106025	Includes #2-5,#12-13
6	FRM-1120C-37	2	bearing (6201)	GB/T276-1994	Includes #6-8, #10-11
7	FRM-1120C-37	2	bearing seat	106085	Includes #6-8, #10-11
8	FRM-1120C-37	2	front roller of conveyor table	106047	Includes #6-8, #10-11
9		1	outfeed plate	106090	
10	FRM-1120C-37	2	sprocket of conveyor table	106089	Includes #6-8, #10-11
11	FRM-1120C-37	1	front shaft of conveyor table	106044	Includes #6-8, #10-11
12	FRM-1120C-41	1	middle shaft of conveyor table	106045	Includes #2-5,#12-13
13	FRM-1120C-41	2	bearing seat of conveyor table middle shaft	101003	Includes #2-5,#12-13
14		2	middle roller of conveyor table		
15		2	middle roller shaft of conveyor table		
16		4	bearing seat		
17		4	bearing sleeve		
18	FRM-1120C-36	1	rear roller of conveyor table	106048	Includes #18-20
19	FRM-1120C-36	1	rear shaft of conveyor table	106046	Includes #18-20
20	FRM-1120C-36	2	bearing (6201)	GB/T276-1994	Includes #18-20
21		2	adjusting seat of conveyor table	106086	
22	FRM-1120C-16	2	adjusting loop of conveyor table	106051	Includes #22-24
23	FRM-1120C-16				Includes #22-24
24	FRM-1120C-16				Includes #22-24
25	FRM-1120C-15	1	working table		

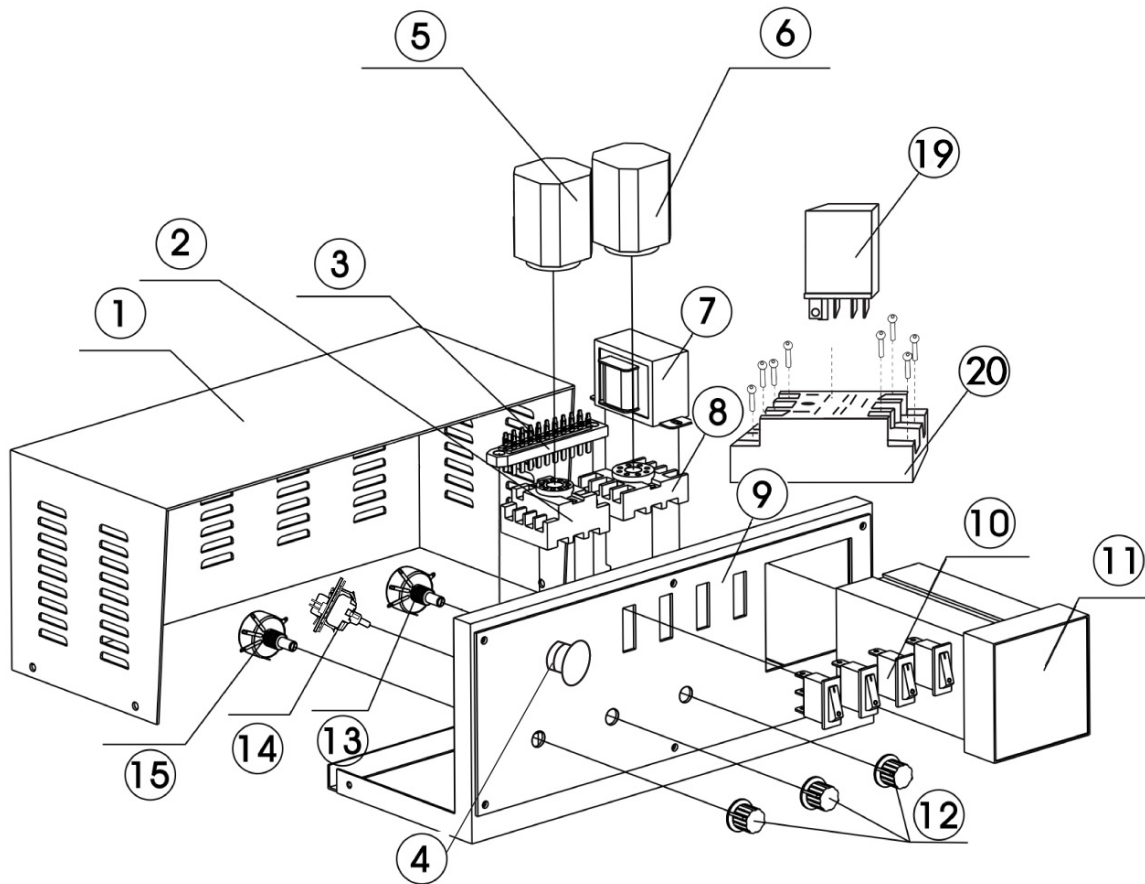

Figure 40. FRM-1120C Controller Box

Figure 41. FRM-1120C Controller Box

Item #	Part #	Quantity	Description	Comments
1		1	rear cover of electric cabinet	
2	BS-45B	1	PF113A relay holder	
3	FRM-1120C-56	1	20 pin socket	
4	BS-22A	1	emergency stop	
5	BS-52C	1	main control PCB	
6	BS-52A	1	speed regulating PCB	
7	BS-66A	1	transformer BK-10/220-13.5V	
8	BS-45A	1	PF083 relay holder	
9		1	control panel	
10	BS-22	1	control switch	specify large or small
11	TMC-XMTE-1000-2	1	temperature controller	determine version by taking temp controller out
	TMC-XMTE-1000-2-0	1	temperature controller	determine version by taking temp controller out
	TMC-E5CSL-QTC-FRM-1120	1	temperature controller	
12	BS-25A	1	knob	
13	BS-51	1	coding potentiometer 1.0M	
14	BS-50A	1	ink temperature potentiometer wih pc board	
	BS-25	1	potentiometer 100K	
15	BS-51	1	coding potentiometer 1.0M	
19	R-JQX-13F	1	Relay	
	R-JG3NA	1	Relay	
20	BS-74A	1	Seat for relay	

Figure 42. Controller Box

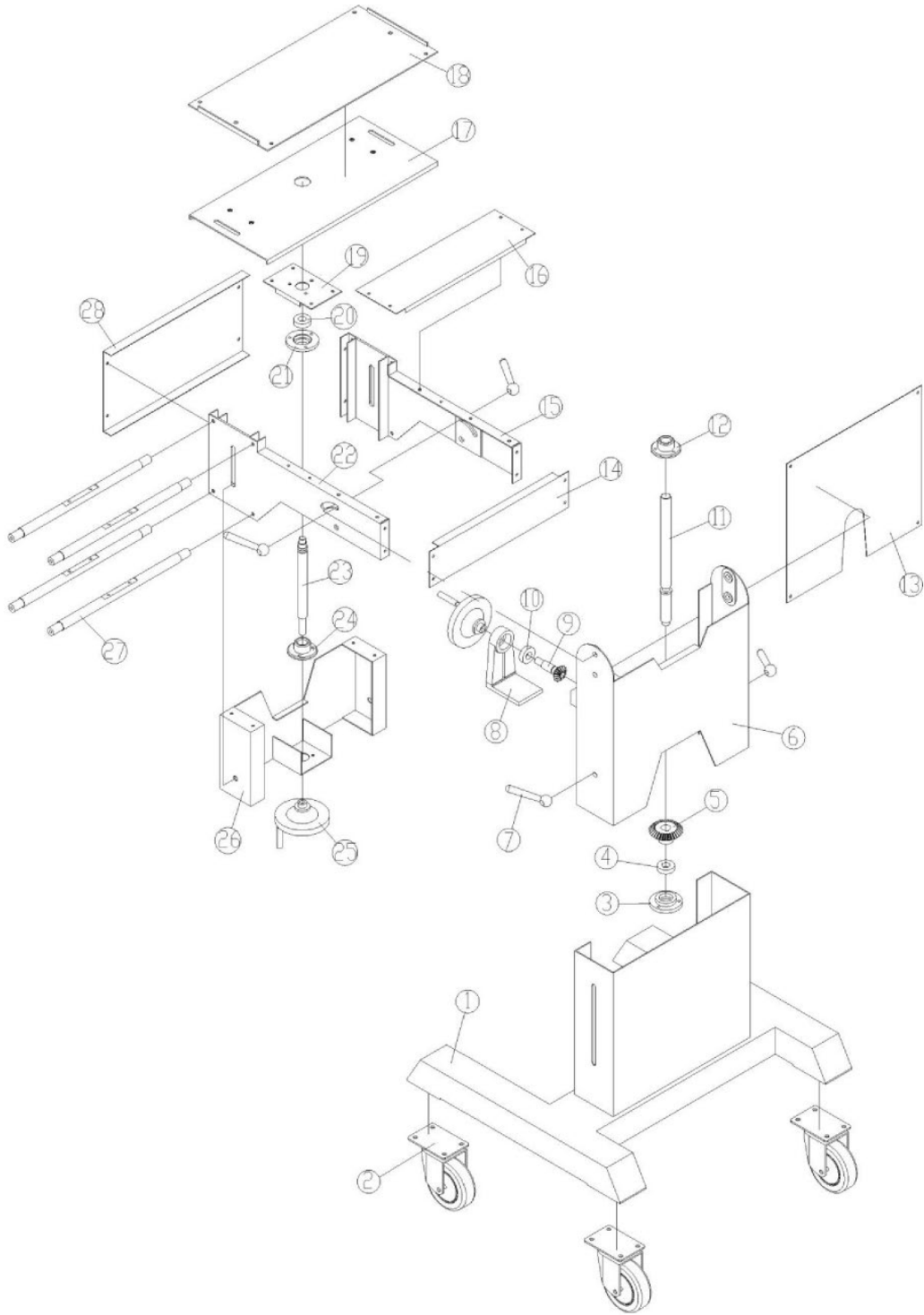

Figure 43. FRM-1120C Sealer Rack

Figure 44. FRM-1120C Sealer Rack

Item #	Part #	Quantity	Description	Reference	Comments
1		1	pedestal		
2		4	caster		
3		1	bearing seat of lifting screw rod	106064	
4		1	bearing (6201)	GB/T276-1994	
5		1	bevel gear	106061	
6		1	lifting slide block		
7		4	lock handle	106063	
8		1	bevel gear seat	106062	
9		1	handle bevel gear	106060	
10		1	bearing (6201)	GB/T276-1994	
11		1	lifting nut	106067	
12		1	lifting screw rod	106065	
13		1	rear cover of pedestal		
14		1	rear cover of bracket		
15		1	bracket		
16		1	upper cover of bracket		
17	FRM-1120C-20-17	1	connecting plate of bracket slide block	11511050009	
18	FRM-1120C-20-18	1	connecting plate of conveyor table	11511050010	
19		1	support plate of bracket		
20		1	bearing (6201)	GB/T276-1994	
21		1	bearing seat for lifting screw rod	106064	
22		1	bracket		
23		1	screw rod of bracket	106066	
24		1	lifting nut for bracket	106067	
25	FRM-1120C-90	1	handwheel	QB8251.2-98	
26		1	slide block of bracket		
27		1	stay bar for bracket		
28		1	front cover of bracket		

FRS-1120W Parts Diagram

To order spare parts, please use diagram and part #s below:

Figure 45. FRS-1120W Spare Parts Overview Diagram

Figure 47. FRS-1120W Heating / Cooling Blocks Parts Diagram

Figure 49. FRS-1120W Motor and Gears Parts Diagram

Figure 51. FRS-1120W Conveyor Parts Diagram

Figure 53. FRS-1120W Control Box Diagram

Figure 55. FRS-1120W Sealer Rack Parts Diagram

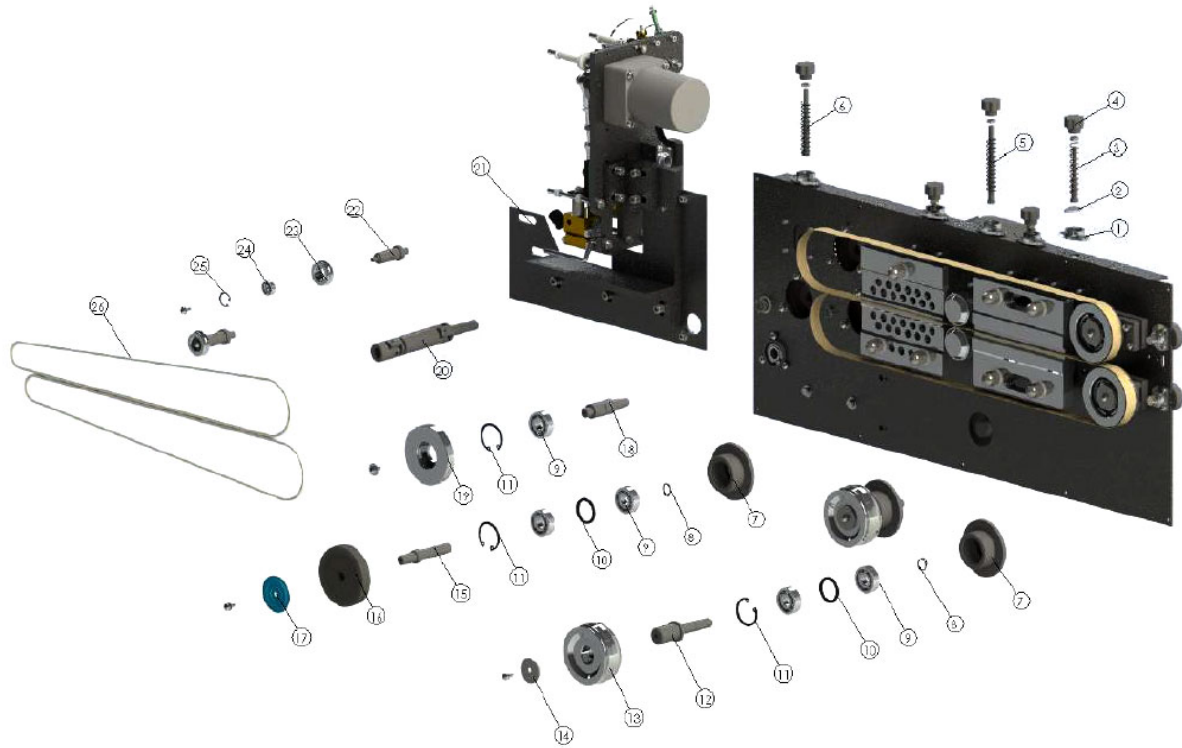

Figure 45. FRS-1120W Spare Parts Overview Diagram

Figure 46. FRS-1120W Spare Parts Overview Parts List

Item	Part #	Quantity	Description	Reference	Comments
1	FRM-1120C-28a, b or c	5	Adjusting Assembly for FRM-1120C, FRS-1120W	11511010203	
2	FRM-1120C-28a, b or c	5	Adjusting Assembly for FRM-1120C, FRS-1120W	11511010204	
3	FRM-1120C-28a, b or c	3	Adjusting Assembly for FRM-1120C, FRS-1120W	11511010205.65	
4	FRM-1120C-28a	5	Adjusting Assembly for FRM-1120C, FRS-1120W - 65mm	9100411120625	Includes #1-4
5	FRM-1120C-28c	1	Adjusting Assembly for FRM-1120C, FRS-1120W - 92mm	11511010205.92	Includes #1-3, 5
6	FRM-1120C-28b	1	Adjusting Assembly for FRM-1120C, FRS-1120W - 78mm	11511010205.78	Includes #1-3, 6
7	FRM-1120C-6-56	3	Bearing Seat	11511010303	
8		3	E-clip 12mm	9746036400012	
9	Bearing_6201Z	7	Bearing 6201 Z (12 x 32 x 10)	9105200602011	
10	FRM-1120C-6-55	3	Spacing Ring of Bearing	11511010304	
11		4	E-Clip 32mm	9746016400032	
12	FRM-1120C-6-53	2	Driving Wheel Shaft	11511010402	
13	FRM-1120C-6	2	Driving Wheel, Big	11511010401	
14	Washer-M5x28	2	Washer M5 x 28 x 2	11511010403	
15		1	Rubber Wheel Shaft	11511010302	
16	FRM-1120C-2	1	Rubber Wheel	11511010301	
17	CBS-880-2-33	1	Silicone Wheel Cover	11111030018	
18	FRM-1120C-3A-10	1	Embossing Wheel Shaft	11511010201	
19	FRM-1120C-3A	1	Embossing Wheel, Meshed	11511010202	
20	FRM-1120C-40A	1	Drive Shaft Connector, Gimbel Assembly	A115110107	
21	FRS-1120W-HP-241G	1	Imprinter for FRS-1120W	A21312105	
	FRS-1120W-48A	1	Print Head for FRS-1120W		
22	FRS-1120W-6B	2	Small Pulley Shaft	11513010101	
23		2	Driving Wheel, Small	11311030001	
24	Bearing_606ZZ	2	Bearing 606-ZZ (17 x 6 x 6)	9105200600062	
25	Circlip-17mm	2	E-Clip 17mm	9746016400017	
26	FRS-1120W-26	2	Drive Belt (#830mm)	9425100020830	

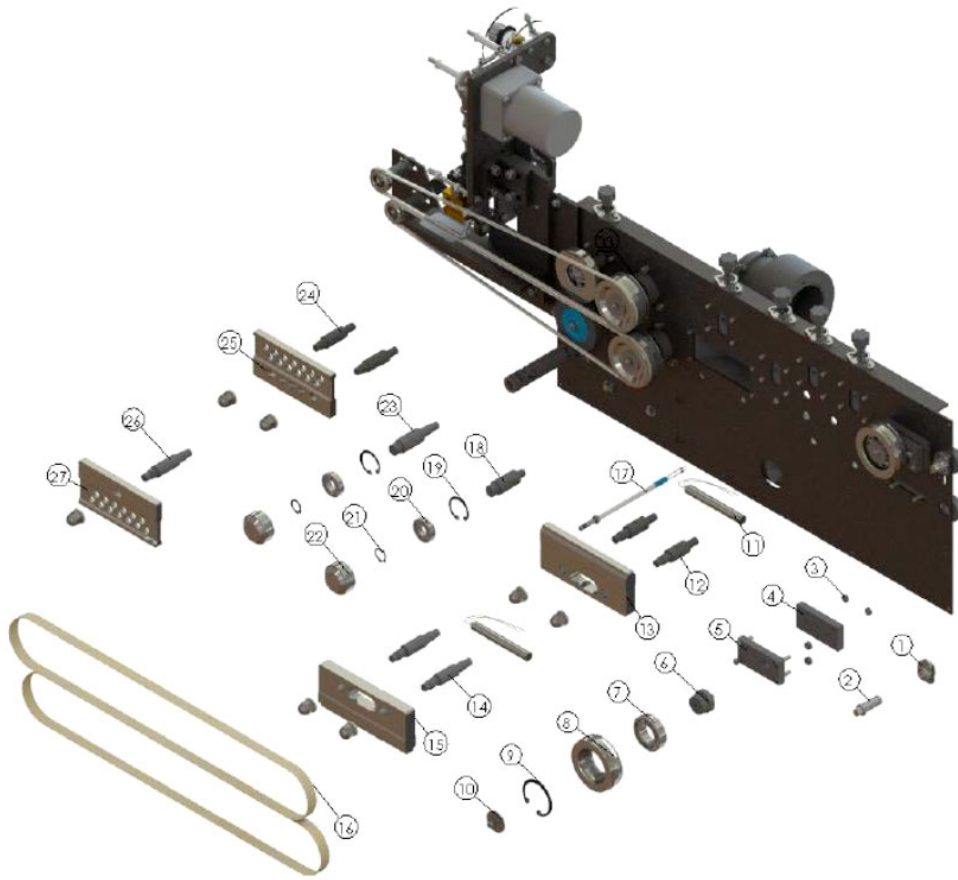

Figure 47. FRS-1120W Heating / Cooling Blocks Parts Diagram

Figure 48. FRS-1120W Heating / Cooling Blocks Parts List

Item #	Part #	Quantity	Description	Reference	Comments
1		2	Cam Shaft Seat	11511011105	
2	FRM-1120C-13-36	2	Cam Shaft	11511011104	
3	FRM-1120C-13-41	8	Spacing Ring of Pressing Plate	11511011108	
4	FRM-1120C-13	2	Adjustment Block Assembly	11511011111	Includes #4, 5
5	FRM-1120C-13	2	Adjustment Block Assembly	11511011112	Includes #4, 5
6		2	Driven Wheel Shaft	11511011102	
7	FRM-1120C-12	2	Bearing 6005-2RS (25 x 47x x12)	9105200601052	Includes #7-9
8	FRM-1120C-12	2	Driven Wheel	11511011101	Includes #7-9
9		2	E-Clip 47mm	9746016400047	Includes #7-9
10	Washer-M5x28	2	Washer M5 x 28 x 2	11511010403	
11	BS-9B	2	Heater		sold as a pair
12	FRM-1120C-9-26	2	Lower Heating Block Shaft	11511011001	
13	FRM-1120C-9A-SS	1	Heating Block	11511011002	Includes #13, 15 - sold as a set
14	FRM-1120C-9-24	2	Upper Heating Block Shaft	11511010902	
15	FRM-1120C-9A-SS	1	Heating Block	11511010901	Includes #13, 15 - sold as a set
16	FRM-1120C-10	2	Sealing Belt (#1120mm)	9430113112015	
17	FRM-1120C-34	1	Thermocouple	9241100021000	
18	FRM-1120C-21-27	1	Lower Pressing Wheel Shaft	11511010801	Includes #18-22
19		2	E-Clip 32mm	9746016400032	Includes #18-22
20		2	Pressing Wheel	9105200601022	Includes #18-22
21		2	E-Clip 15mm	9746036400015	
22		2	Bearing 6002 ZZ (15 x 32 x 9)	11511010702	
23	FRM-1120C-21-22-26	1	Upper Pressing Wheel Shaft	11511010701	Includes #18-21, 23
24	FRM-1120C-8-22	2	Lower Cooling Block Shaft	11511010602	
25	FRM-1120C-8-SS	1	Cooling Block	11511010601	Includes #25, 27 - sold as set
26	FRM-1120C-8-18	1	Upper Cooling Block Shaft	11511010502	
27	FRM-1120C-8-SS	1	Cooling Block	11511010503	Includes #25, 27 - sold as set

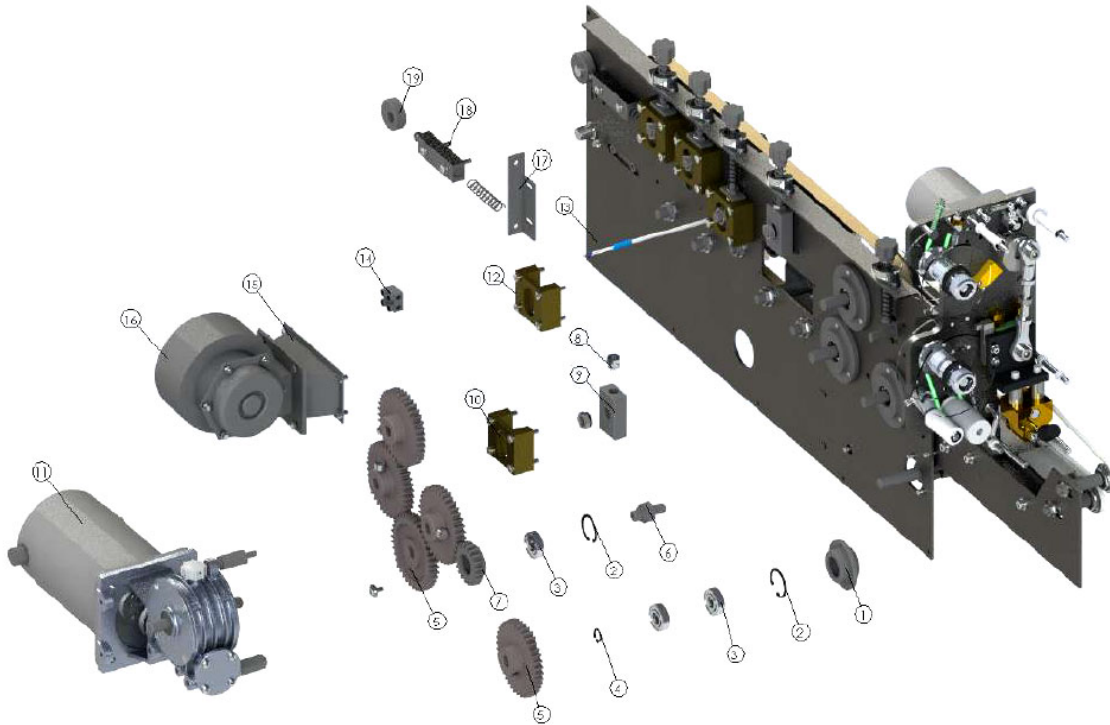

Figure 49. FRS-1120W Motor and Gears Parts Diagram

Item #	Part #	Quantity	Description	Reference	Comments
1	HL-M810-40C	1	Connecting Shaft Bearing Seat	11311030026	Includes #1, 2, 3
2	HL-M810-40C	2	E-Clip 28mm	9746016400028	Includes #1, 2, 3
3	HL-M810-40C	3	Bearing 6001 ZZ (12 x 28 x 8)	9105200601012	Includes #1, 2, 3
4		1	E-Clip 12mm	9746036400012	
5	FRM-1120C-35b		Wheel Gear (with out groove)	11511010305	
	FRM-1120C-35c		Wheel Gear (with groove)	11511010305C	
6		1	Wheel Shaft	11511011202	
7	FRM-1120C-35-68	1	Medium Gear	11511011201	
8		5	Slide Spring Seat	11511010207	
9	FRM01129C-28-66	5	Spring Seat for Slide Block	11511010208	
10		1	Slide Block Seat	11511010209A	
11	FRM-1120C-29	1	Motor		
	FRM-1120C-30		Turbocase		
12	FRM-1120C-28-49	4	Slide Block Seat	11511010209	
13		1	Bottom Plate	11513011303	
14	BS-33A	1	Connection Station (4P)	9201401110002	
15	FRM-1120C-32	1	Fan	11511020011	Includes #15, 16
16	FRM-1120C-32	1	Fan	9230121000765	Includes #15, 16
17	FRM-1120C-13-46	1	Adjusting Block Seat	11511011110	
18	FRM-1120C-13-40	2	Adjusting Pressing Plate	11511011107	
19	FRM-1120C-13-38	2	Cam / Protruding Wheel	11511011106	

Figure 50. FRS-1120W Motor and Gear Parts List

FRM-1120C INSTRUCTION MANUAL

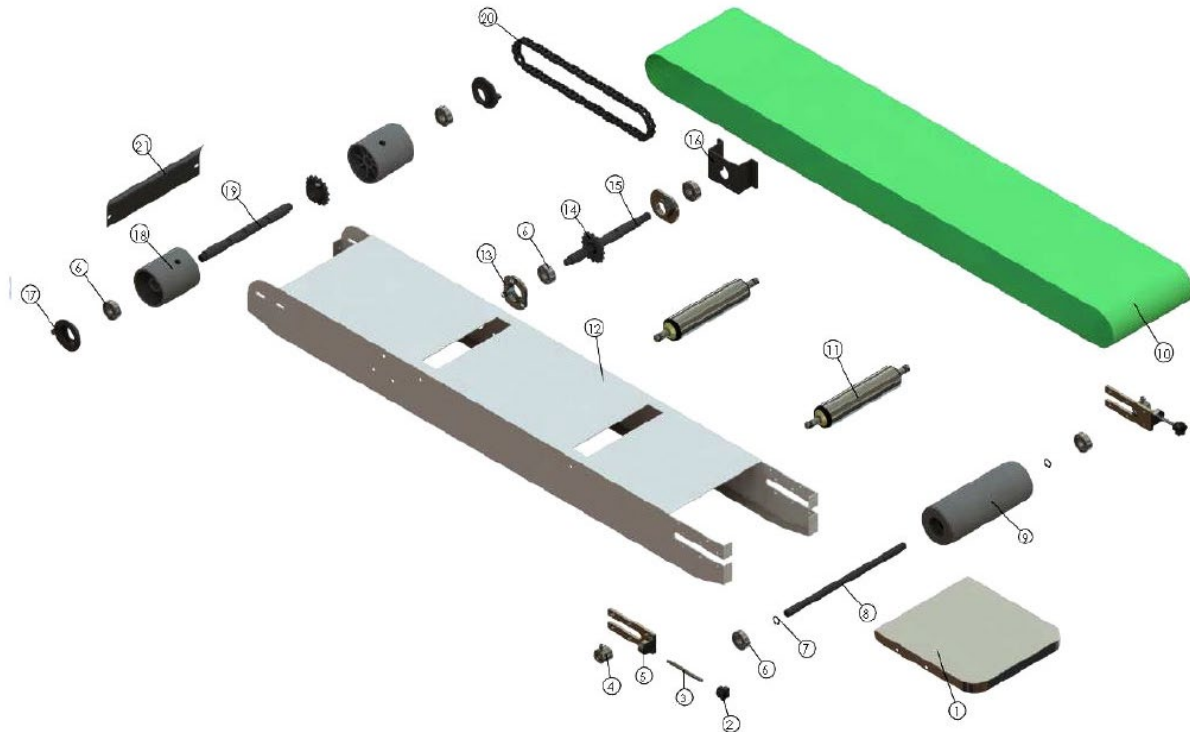

Figure 51. FRS-1120W Conveyor Parts Diagram

Item #	Part #	Quantity	Description	Reference	Comments
1	FRM-1120C-15	1	Working Table	11511030002	
2	FRM-1120LD-16	2	Adjusting Knob	9100402140632	Includes #2, 3, 4
3	FRM-1120LD-16	2	Adjusting Screw	11511030403.01	Includes #2, 3, 4
4	FRM-1120LD-16	2	Adjusting Loop	11511030403	Includes #2, 3, 4
5	FRM-1120LD-16-15	2	Adjusting Seat	11511030404	
6	FRM-1120C-36	6	Bearing 6201-2RS	9105200602012	Includes #6-9
7	FRM-1120C-36	2	E-Clip 12mm	9746036400012	Includes #6-9
8	FRM-1120C-36	1	Conveyor Roller Shaft, Right	11511030402	Includes #6-9
9	FRM-1120C-36	1	Conveyor Roller, Right	11511030401	Includes #6-9
10		1	Conveyor Belt 2080 x 175 x 2	9422112208173	
11		2	Intermediate Roller Shaft	A115110304	
12		1	Conveyor	11513030001	
13	FRM-1120C-41	2	Middle Post	11111010014	Includes #6, #13-16
14	FRM-1120C-41	2	Gear	11511030104	Includes #6, #13-16
15	FRM-1120C-41	1	Shaft	11511030201	Includes #6, #13-16
16	FRM-1120C-41	1	Conveyor Middle Post with Gear	11511030203	Includes #6, #13-16
17	FRM-1120C-37	2	Front Roller Bearing	11511030102	Includes #6, #17-19
18	FRM-1120C-37	2	Conveyor Roller, Left	11511030103	Includes #6, #17-19
19	FRM-1120C-37	1	Shaft	11511030101	Includes #6, #17-19
20		1	Chain (06B-1 x 69L)	9104101106069	
21	FRM-1120C-1-9	1	Outfeed Plate	11511030003	

Figure 52. FRS-1120W Conveyor Parts List

FRM-1120C INSTRUCTION MANUAL

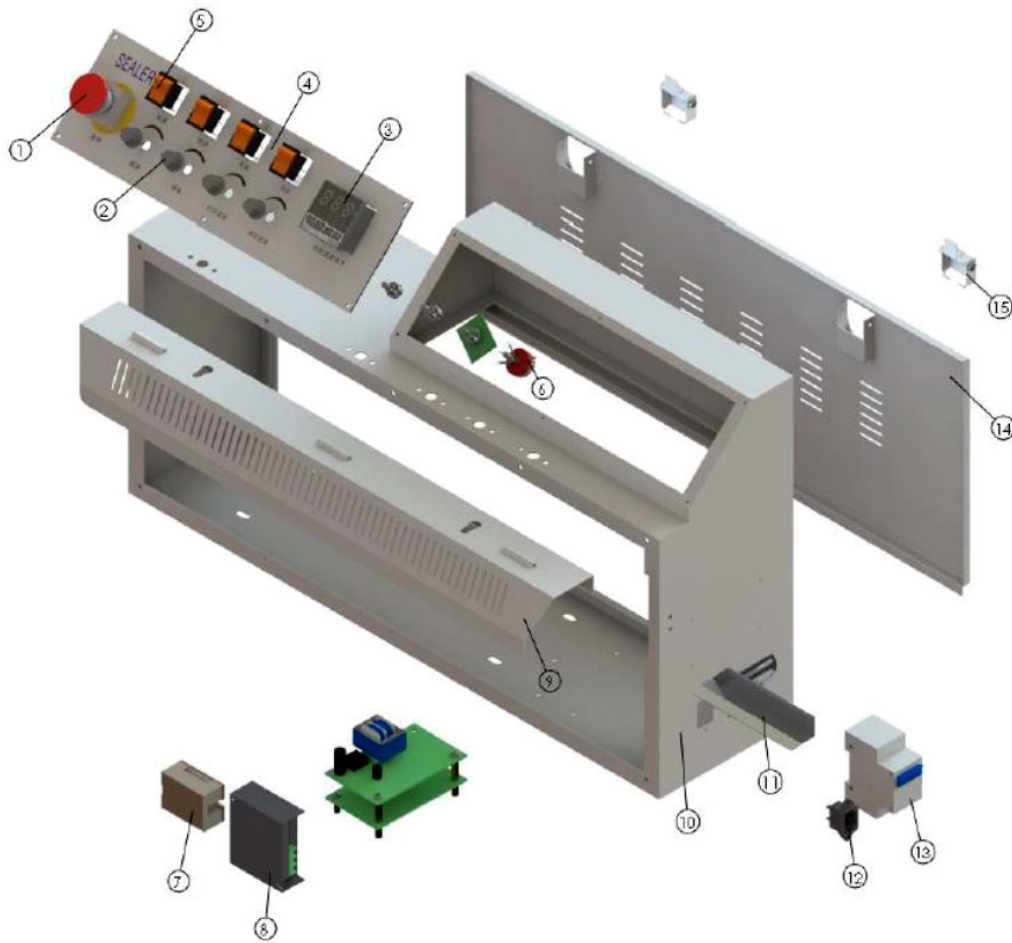

Figure 53. FRS-1120W Control Box Diagram

Item #	Part #	Quantity	Description	Reference	Comments
1	BS-22A_G	1	Emergency Stop, Green / Green	9212232220640	
	BS-22A_O	1	Emergency Stop, Orange / Green		
2	BS-25A	4	Knob	9210200100004	
3	TMC-E5CSL-QTC	1	Temperature Controller	9241131305325	
4		1	Font Panel Plate	9160103115412	
5	BS-22-LARGE	4	Switch, Large	9212240130395	
6	BS-25A	1	Speed Potentiometer	9300112520100	
7	Relay-JG3NA	1	Relay JG3NA-2255B	9215301102252	
8	FRM-1010-31	1	Speed PC Board	9310121115015	
9		1	Guard	11513020005	
10		1	Body	11513020001	
11	FRM-1120C-44	1	Sealing Width Adjusting Guide	11511020101	
12	BS-14	1	Socket for Power Cord	9201111031002	
13	BS-27	1	Circuit Breaker	9212711602005	
14		1	Back Cover	11513020004	
15		2	Door Latch	1151102001381	

Figure 54. FRS-1120W Control Box Parts List

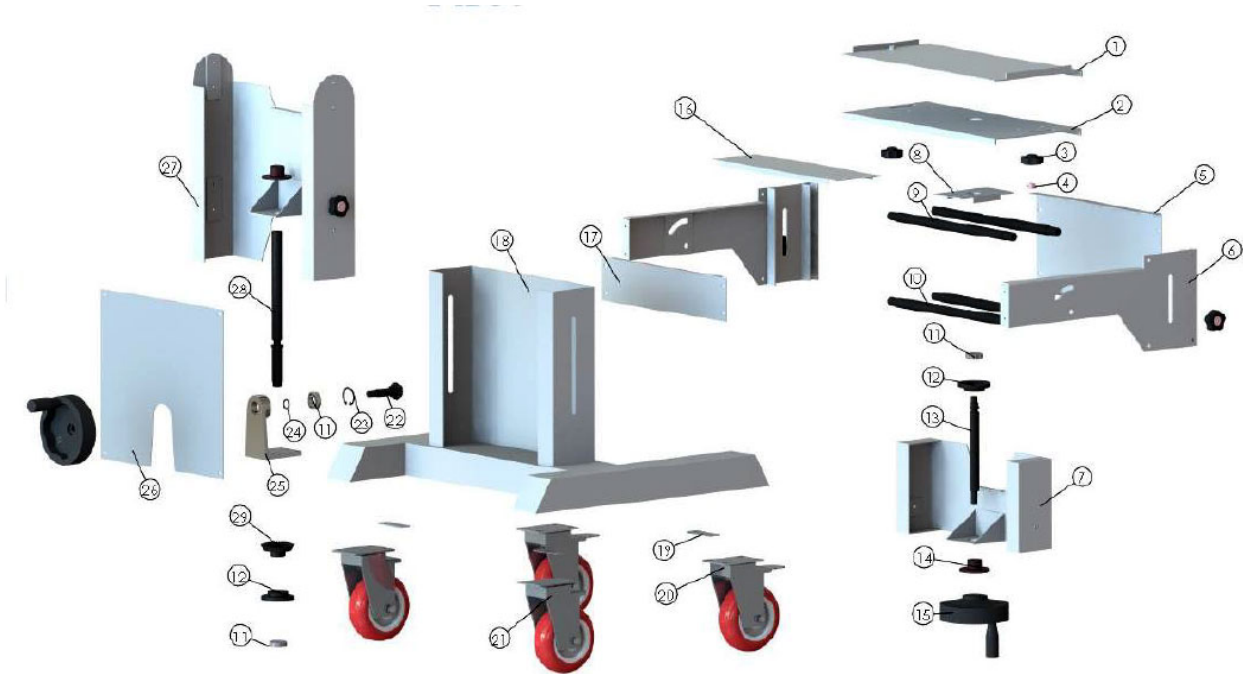

Figure 55. FRS-1120W Sealer Rack Parts Diagram

Item	Part #	Quantity	Description	Reference	Comments
1		1	Conveyor Connecting Plate	11511050010	Compatible with FRM-1120C
2		1	Bracket Slider Connecting Plate	11511050009	Compatible with FRM-1120C
3	BS-5_Gen2.0	6	Pressure Adjusting Knob	9450101111004	Includes #3, 4
4	BS-5_Gen2.0	6	Pressure Adjusting Knob	9450101111003	Includes #3, 4
5		1	Bracket Front Cover	11511050002	Compatible with FRM-1120C
6		2	Side Bracket	11511050003	Compatible with FRM-1120C
7		1	Mid Bracket Slider	11511050004	Compatible with FRM-1120C
8		1	Bracket Support	11511050008	Compatible with FRM-1120C
9		2	Upper Bracket Shafts	11511050001	Compatible with FRM-1120C
10		2	Lower Bracket Shafts	11511050001-D2	Compatible with FRM-1120C
11	Bearing_6002Z	3	Bearing 6002 ZZ (15 x 32 x 9)	9105200601022	
12		2	Lifting Bracket Bearing Housing	11511040007	Compatible with FRM-1120C
13		1	Lifting Bracket Shaft	11511050006	Compatible with FRM-1120C
14		2	Lifting Bracket Nut	11511040004	
15	FRM-1120C-90	2	Handwheel	9100303112100	
16		1	Top Bracket Cover	11511050011	Compatible with FRM-1120C
17		1	Back Bracket Cover	11511050012	Compatible with FRM-1120C
18		1	Base	11511040001	Compatible with FRM-1120C
19		4	Caster Support	11510000099	
20	FRM-1120C-92B	2	Casters With Brake	9400102410403	
21	FRM-1120C-92A	2	Casters Without Brake	9400102400403	
22		1	Handle Bevel Gear	11511040009	Compatible with FRM-1120C
23		1	E-clip 32mm	9746016400032	
24		1	E-clip 15mm	9746036400015	
25		1	Bevel Gear	1151140005	Compatible with FRM-1120C
26		1	Base Back Cover	11511040006	Compatible with FRM-1120C
27		1	Lifting Slider	11511040002	Compatible with FRM-1120C
28		1	Lifting Slider Shaft	11511040003	Compatible with FRM-1120C
29		1	Bevel Gear	11511040008	

Figure 56. FRS-1120W Sealer Rack Parts List

Troubleshooting

Changing Emergency Stop

Always unplug the unit from the power source when making adjustments.

Problem: The emergency stop (Part #BS-22A_Gen3.0) needs to be replaced



For our smaller band sealers (CBS-880, FR-770, HL-M810, FRM-1010 units), remove the control panel plate from the band sealer. Place the control panel on top of the band sealer for better viewing.

For our larger band sealers (FRM-1120C, FRS-1120W, HL-M1120LD units), remove the control box cover to access the back of the control panel.

1. To remove Gen 3.0 emergency stop, click the yellow tab in release position.



Locked position

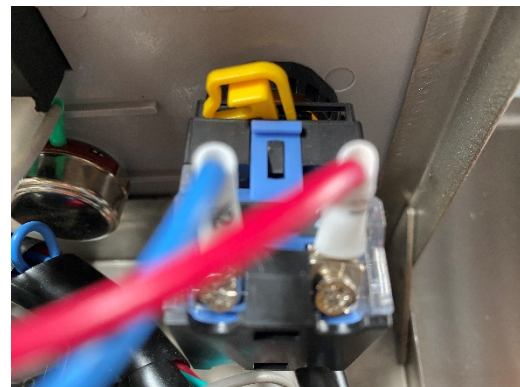

Release Position

2. Remove the contact block from the push button. The push button can be removed by loosening the black nut.

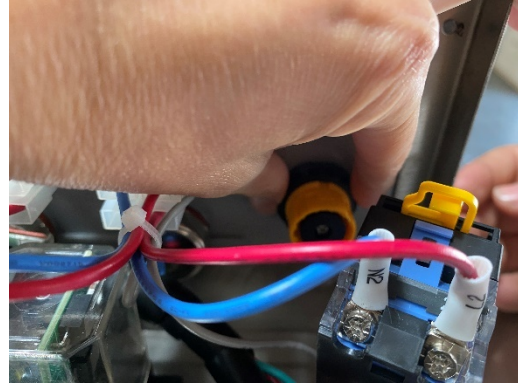
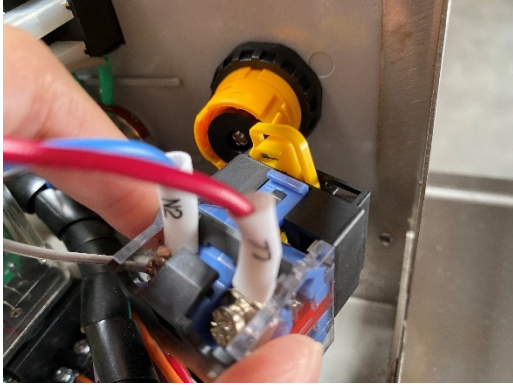

3. Make note of the wiring on the emergency stop and reconnect the new emergency stop. Blue wires connect to 11 and 12 and the red wires connect to 21 and 22





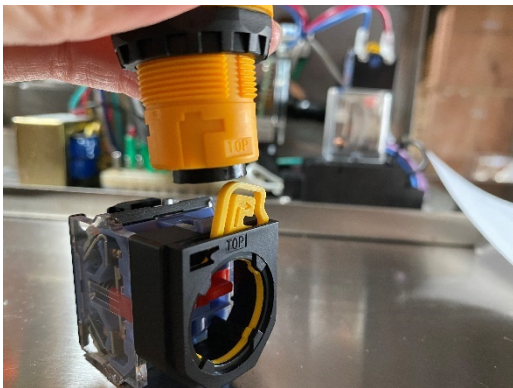

4. Connect the contact block to the push button. Match the two pieces where they are labeled top. Push the yellow tab into the locked position.





Unable to Set Temperature Controller

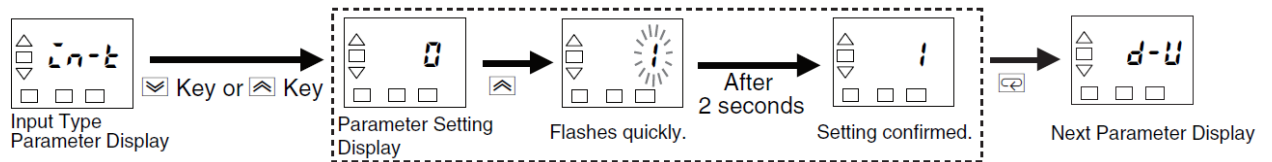

If operator is unable to set the temperature or is finding the temperature settings inaccurate, we suggest resetting the temperature controller to the default settings. Please follow the following steps:

- ❖ Hold the  for at least three seconds.
- ❖ Press the  or  key at the display for the parameter for which the setting is to be changed. The parameter setting display will appear. Use the  or  key to change the setting. Example: Changing the Input Type from 0 to 1 is below:



- ❖ Enter  to move on to the next parameter display.
- ❖ To save the settings, hold  again for more than three seconds. The temperature controller will automatically restart and save the settings.
- ❖ **Please note: This temperature controller can only be set to Celsius. If you try and change the temperature unit to F, the temperature controller will not function properly.**

Sheet 1: Initial menu		
data	note	Set value
in-t	Input type	0
d-U	Temperature unit	ℓ
Ctrl	Control mode PID or ON/OFF	Pid
CP	Control cycle	3
orEu	Forward / reverse operation	or-r

Figure 57. Default Setting Parameters

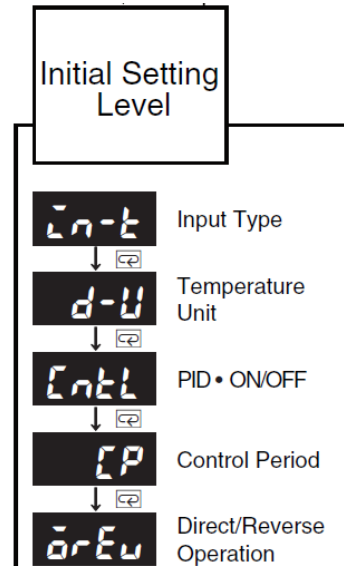

Figure 58. Parameter Displays

Printing Wheel Adjustments

Problem: Print wheel on the band sealer rotates more than once.

Possible Cause: Electromagnetic clutch on the back of the unit and groove sensor are not aligned properly. The flat panel of the electromagnetic clutch signals the groove sensor to stop the print wheel rotation.

1. We suggest the following steps:
2. Loosen the nut as shown in [Figure 59](#). This will allow the carbon brush holder and groove sensor some movement.
3. Push the groove sensor closer to the electromagnetic clutch
4. Re-tighten the nut

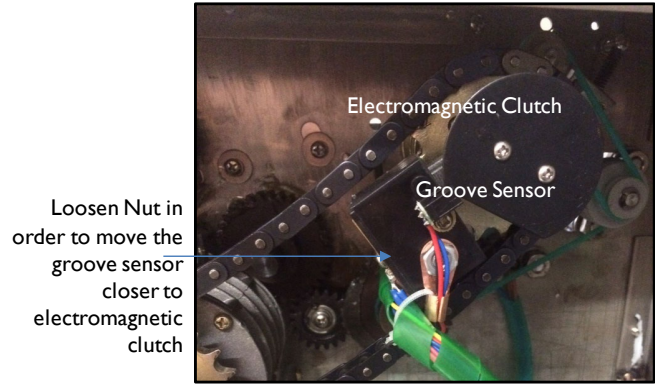

Figure 59. Incorrect position of groove sensor and electromagnetic clutch

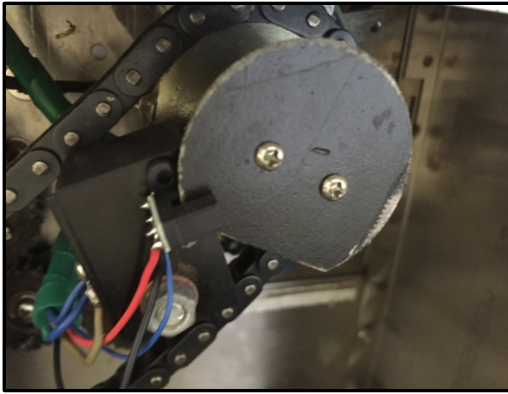

Figure 60. Correct position of groove sensor and electromagnetic clutch

Problem	Possible Causes	Solution
Sealing belt is off tracking.	Driving wheel shaft is not parallel to driven wheel shaft	Adjust two adjusting screws on the adjusting block seat (Part# FRM-1120C-13)
Sealing belts are tearing	<ol style="list-style-type: none"> 1. Too much tension on sealing belt 2. Sealing belt is off tracking 3. Creases on the sealing belt 4. Residual film or other debris attached to the sealing belt 	<ol style="list-style-type: none"> 1. Adjust the vertical adjusting screw on driven wheel seal to decrease tension on sealing belt 2. see above 3. When installing belt, make sure no creases are found on belt 4. Clean surface of belt with cloth
Seal is crumpled and film sticks to sealing belts	<ol style="list-style-type: none"> 1. Temperature is too high 2. Guide belt is not correctly in place 3. Plastic melted on the sealing belt 	<ol style="list-style-type: none"> 1. Reduce temperature 2. Adjust guide belt 3. Clean or replace sealing belt <p>If any plastic melts on the sealing belt, your bags will stick to the melted plastic</p>
Embossing is not clear	<ol style="list-style-type: none"> 1. Embossing roller is worn out 2. Pressure spring on embossing roller needs to be tightened 	<ol style="list-style-type: none"> 1. Replace embossing roller 2. Adjust the embossing roller spring (Part# FRM-1120C-28B)
Material will not pass through sealing blocks	Clearance between heating blocks or cooling blocks may be too small	Adjust the clearance between blocks by adjusting the springs and stopping flakes found above the blocks
Conveyor belt is off tracking	Driving roller shaft is not parallel to the driven roller shaft	Adjust using the conveyor belt adjustment (Part# FRM-1120C-16)
Conveyor and sealing belt are not moving at same speed	Not enough tension on conveyor belt	<ol style="list-style-type: none"> 1. Tighten the chain of driving roller shaft (front shaft) and middle shaft. (Parts # FRM-1120C-37 and FRM-1120C-41) 2. Tighten the conveyor belt
Temperature doesn't rise or cannot be controlled	<ol style="list-style-type: none"> 1. Heat switch is damaged 2. Heater (BS-9B) is damaged 3. Temperature Controller 4. Coupling 	Replace: <ol style="list-style-type: none"> 1. Heat switch (BS-22-Large) 2. Heater (BS-9B) 3. Temperature Controller 4. Thermocouple (FR-1120C-34)

Problem	Possible Causes	Solution
Printing wheel does not rotate	<ol style="list-style-type: none"> 1. Sensor is blocked 2. Sensor is not clean and eye is blocked by dust 	<ol style="list-style-type: none"> 1. Make sure sensor is not blocked 2. Clean sensor 3. Replace PCB (BS-52C)
Printing wheel does not stop rotating	<ol style="list-style-type: none"> 1. Sensor (groove) is damaged or dirty 2. Photoelectric sensor is damaged or dirty 3. Main control PC Board is damaged 	<ol style="list-style-type: none"> 1. Replace or correct position of the groove sensor or clean its surface (BS-65) 2. Replace or clean photoelectric sensor (BS-60) 3. Replace PC Board (BS-52C)
No heat on the ink heating block	<ol style="list-style-type: none"> 1. Heating element in heating block is damaged 2. Heating PCB is damaged 3. Potentiometer w/ PC Board (BS-50A) is damaged 4. Carbon brush is not in place 5. Carbon brush is damaged 	<ol style="list-style-type: none"> 1. Replace element (BS-48C) in heating block 2. Replace PCB (BS-50A) 3. Replace potentiometer with PC Board (BS-50A) 4. Adjust and tighten nut on carbon brush seat 5. Replace carbon brush
Temperature of heating block for ink roller cannot be regulated	Relay for temperature control PCB is damaged	Check and replace temperature control PCB (BS-50A)
Printing position cannot be regulated	<ol style="list-style-type: none"> 1. Tighten screw on printing wheel 2. Coding seat potentiometer may be damaged 	<ol style="list-style-type: none"> 1. Tighten screw on printing wheel. 2. Replace coding seat potentiometer (BS-51)
Motor runs at a high speed and cannot be regulated	Speed controller has malfunctioned	Replace the speed controller (BS-52A)
Power, heater, and or fan switches do not light up	<ol style="list-style-type: none"> 1. No AC Voltage 2. Open Fuse 3. Lamp is damaged 	<p>Check power source / power cord Connect the power Replace the fuse Replace the lamp</p>

Problem	Possible Causes	Solution
Machine does not run	<ol style="list-style-type: none"> 1. Board for speed regulation is abnormal 2. Doesn't connect well 3. Brushes in the motor are too short because of friction 	<ol style="list-style-type: none"> 1. Replace the speed board (BS-52A) 2. Tighten the connecting screws 3. Replace motor brushes (BS-29A) <p>If the temperature controller works and the power lamp illuminates but the motor does not move, start off by checking the motor and turbocase connection. Remove the back of the machine and you will see bushing where the motor connects to the gear box. Ensure the bushing is not broken. There is also a set screw that connects the bushing to the gear box / motor shafts. Ensure that these are tight so that when the motor turns, the turbocase turns as well.</p> <p>If the turbocase is noisy before it stopped working, the gear box could be broken inside. Lack of oil could cause this.</p> <p>If the lamp illuminates and the motor does not turn, the motor speed controller may need to be replaced.</p>

Spare Parts List

Included with your band sealer are the following parts. Please note that spare parts included with your band sealer are subject to change without notice.

- ❖ Typeset Box which includes numbers (0-9), Letters – EXP, MFD, silicone pins (Part# BS-59), tweezers, and allen wrench
- ❖ Power Cord (Part# PWC-CBS)
- ❖ PTFE Sealing Belts (Part# FRM-1120C-10)
- ❖ Drive Belts (Part# FRM-1120C-26)
- ❖ Speed Adjusting PC Board (Part# BS-52A)
- ❖ Central Circuit PC Board (Part# BS-52C)
- ❖ Ink Temperature Potentiometer with Heat PC Board (Part# BS-50A)
- ❖ O-Rings (Part#s BS-53 and BS-54)
- ❖ Silicone Ring (Part#BS-57A)
- ❖ Ink Roller Holder (Part# BS-58)
- ❖ Ink Rollers, 15mm (Part# IT-IR-15-BLK)
- ❖ Groove (Trough) Sensor (BS#BS-65)
- ❖ Carbon Brush for Printer (BS#64)
- ❖ Philips Screwdriver
- ❖ Flat Screwdriver
- ❖ Allen Wrench (3mm and 5mm)
- ❖ Wrench

Quality Control Testing

Our band sealers are manufactured in a facility which is certified in accordance with ISO 9001:2008. In addition, we quality test all of our band sealers in our facility following a rigorous and exacting standards to ensure that the product you purchased is a high quality reliable machine.

✓ Steps	Description
	Inspect all wiring on the unit, nothing is loosely attached. Make sure all wires are connected correctly.
	Make sure all connections are tight and properly mounted. (Ex: PC Board, Relay)
	Check parts to ensure they are in proper working order (ex: wheels, belts, knobs, etc)
	CBS-880 only - Attach the conveyor to the body via the drive shaft (Part #40). Detach after testing.
	Turn on machine - start, seal, fan, printer Check all knobs to make sure they start and end in the correct position
	Make adjustments as necessary if there is any unusual noise. Noise should be under 80db.
	Check fan - There should be air coming out of the cooling blocks
	Check motor - motor brushes should be held in tightly
	Check conveyor belt to make sure the belt is running smoothly and evenly
	Run machine for at least 20 minutes - after the seal temperature has been reached, seal bag sample to ensure good quality seal
	<u>Band Sealers w/ Printing Option:</u>
	Printing - make sure ink heating block, ink printing wheel are at optimal heat temperature
	Sensor and Coding Seat - test the sensor and coding seat are working properly; make adjustments as necessary
	Clean machine
	Enter serial # of the unit in the manual
	Repackage sealer w/ QC form, sealed bag / printed sample and manual.

Date:

Technician:

